

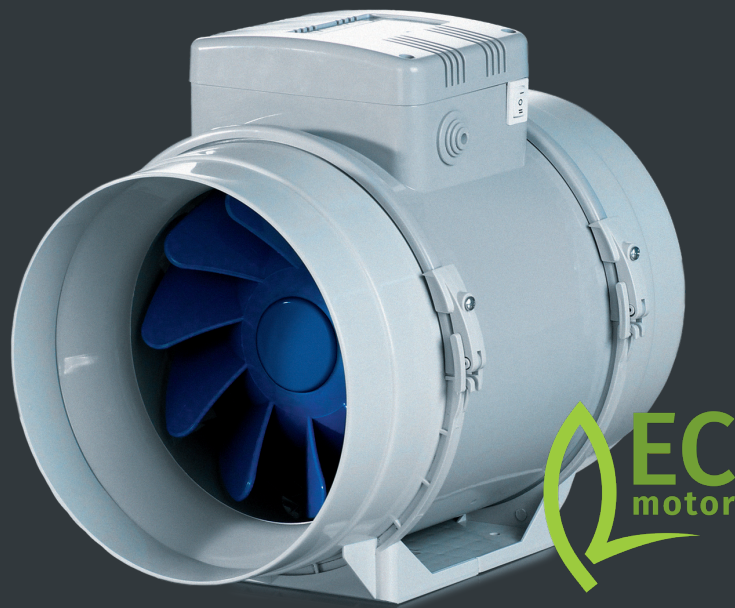

TURBO EC

Data sheet Version 1.0



Turbo EC

Mixed-type duct fans

USE

- Designed for supply and exhaust ventilation systems requiring high energy efficiency, excellent response, high pressure and air flow rate while keeping noise under control – such as high-humidity commercial and industrial spaces (e.g. bathrooms and kitchens) as well as flats, villas, shops and cafes.
- Compatible with air ducts from 100 to 315 mm in diameter.



Air flow:
up to 1995 m³/h
554 l/s



Power:
from 32 W



Noise level:
from 47 dBA



DESIGN

- Turbo EC fans combine the versatility and outstanding performance of both axial and centrifugal fans producing a powerful air flow and high pressure while retaining the signature energy-efficiency and response of EC motors.
- The casing of Turbo EC fan is made of low-combustible polypropylene. The removable central unit with a motor, impeller and terminal box is attached to the fittings by means of special mounting brackets with integral latches. This helps to make the fan maintenance extremely simple and convenient. Fan service no longer requires major disassembly and dismantling of the fan: all you have to do is remove the main unit from the casing and carry out the maintenance as required.
- The inlet fitting has a profiled header which ensures smooth air flow into the fan. Conically shaped impelles with specially profiled blades cause circular velocity rise, that results in airflow boost and pressure increase comparing to conventional design.
- The fan outlet combination of a diffuser, specially designed impeller and rectifier allow for the optimim air distribution: high air capacity and pressure without excessive noise.

SPEED CONTROL

- The fans are controlled by means of a 0-10 V control signal while the performance regulation is based on the feedback from the temperature, smoke and other sensors as well as other vital parameter settings. As the control signal changes the EC fan changes speed accordingly to supply the exact air amount required by the ventilation system.
- The maximum fan speed does not depend on the electric mains frequency enabling compatibility with both 50 Hz and 60 Hz networks. The fans can be easily combined into a single computer-controlled network. Special software allows for precise control over the operating parameters of the network units. All the system parameters can be monitored from the computer screen allowing to program operating parameters for each fan on the network individually.
- Integration of several fans into a single computer-controlled system with sensor feedback combined with speed control across the entire dynamic range.

MOTOR

- The fans feature high-efficiency electronically commutated (EC) direct current motors. These state-of-the-art units offer excellent energy efficiency. In addition to that EC motors combine high performance and optimum response over the entire speed range. The performance efficiency of electronically commutated motors reaches a staggering 90%.

MOUNTING

- The fans are intended for installation in matching diameter air ducts at any point of the ventilation system without limitation to mounting angle
- The fan casing has a flat mounting plate for a secure wall mounting.
- Electrical connection and installation must be performed in accordance with the instruction manual and the electrical connections diagram applied to the terminal box.
- A single system may have several fans installed in parallel to boost the output capacity or in series to boost the working pressure.

Designation key

Series	Motor type	Duct diameter [mm]
Turbo	EC: electronically commutated motor	100; 125; 150; 160; 200; 250; 315

Accessories

Silencer	Panel filter	Pocket filter	Electric heater	Water heater	Backdraft air damper	Shutter	Clamp	Speed controller
SD	KFBK	KFBT	EKH	WKH	VRV	VKA	K	CDT E/0-10

OVERALL DIMENSIONS [mm]

Type	∅D	B	H	L	Weight [kg]
Turbo EC 100	98.0	192.0	241.0	302.5	1.75
Turbo EC 125	123.0	193.0	241.0	258.5	2.15
Turbo EC 150	148.0	216.5	253.5	289.0	2.30
Turbo EC 160	158.0	216.5	253.5	289.0	3.25
Turbo EC 200	198.0	239.0	277.5	295.5	3.95
Turbo EC 250	247.0	288.0	339.0	383.0	7.80
Turbo EC 315	308.5	360.0	423.0	443.0	11.95

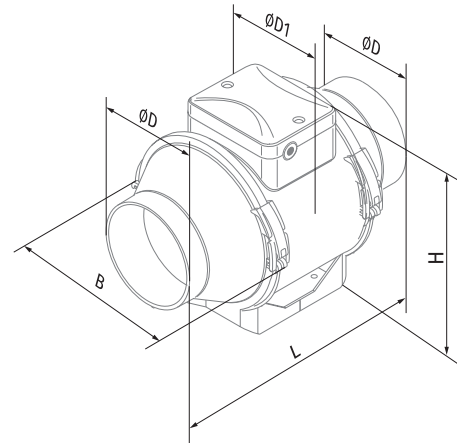

TECHNICAL DATA

Parameters	Turbo EC 100
Voltage [V / 50-60 Hz]	1 ~ 230
Power [W]	32
Current [A]	0.29
Maximum air flow [m³/h (l/s)]	300 (83)
RPM [min⁻¹]	3018
Sound pressure at 3 m [dBA]	47
Transported air temperature [°C]	-25...+55
SEC class	B
Ingress protection rating	IPX4
Motor IP rating	IP44
ErP	2015, 2016, 2018

TURBO EC 100

Sound power level, A-weighted	Octave frequency bands [Hz]									LpA, 3 m dBA	LpA, 1 m dBA
	Gen.	63	125	250	500	1000	2000	4000	8000		
LWA to input [dBA]	74	42	55	62	70	69	66	58	52	54	63
LWA to output [dBA]	69	33	42	59	66	63	62	57	50	49	59
LWA surrounding [dBA]	67	27	45	55	65	62	60	49	38	47	57

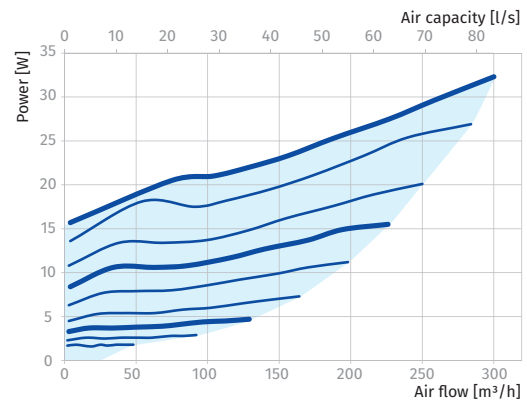
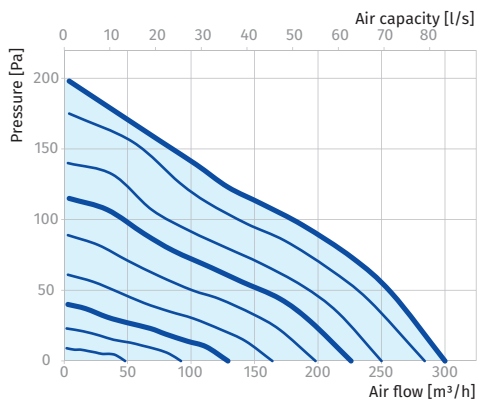

Parameters	Turbo EC 125	Turbo EC 150(160)	Turbo EC 200	Turbo EC 250	Turbo EC 315
Voltage [V / 50-60 Hz]	1 ~ 230	1 ~ 230	1 ~ 230	1 ~ 230	1 ~ 230
Power [W]	45	65	140	197	306
Current [A]	0.39	0.53	0.99	1.35	2.00
Maximum air flow [m³/h (l/s)]	465 (129)	602 (167)	1095 (304)	1500 (417)	1995 (554)
RPM [min ⁻¹]	3036	3018	2880	2784	2508
Sound pressure at 3 m [dBA]	52	47	49	53	55
Transported air temperature [°C]	-25...+55	-25...+55	-25...+55	-25...+55	-25...+55
SEC class	B	B	-	-	-
Ingress protection rating	IPX4	IPX4	IPX4	IPX4	IPX4
Motor IP rating	IP44	IP44	IP44	IP44	IP44
ErP	2016, 2018	2016, 2018	2016, 2018	2016, 2018	2016, 2018

TURBO EC 125

Sound power level, A-weighted	Octave frequency bands [Hz]									LpA, 3 m dBA	LpA, 1 m dBA
	Gen.	63	125	250	500	1000	2000	4000	8000		
L _{WA} to input [dBA]	74	43	51	61	70	68	70	61	53	54	64
L _{WA} to output [dBA]	69	33	48	57	65	64	64	59	51	49	59
L _{WA} surrounding [dBA]	72	29	44	55	72	59	61	48	34	52	62

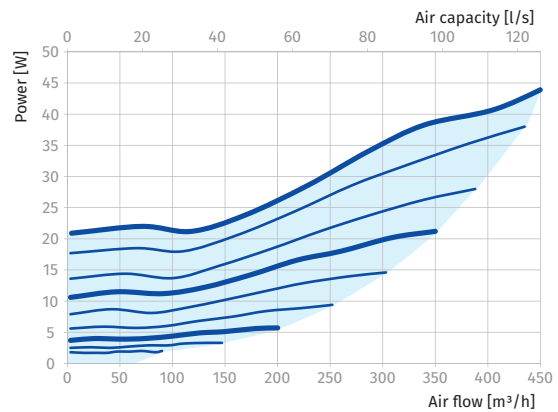
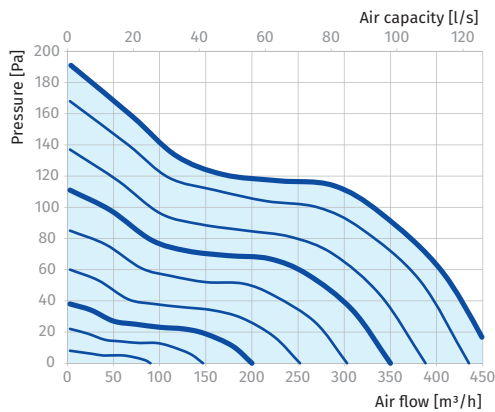

TURBO EC 150 (160)

Sound power level, A-weighted	Octave frequency bands [Hz]									LpA, 3 m dBA	LpA, 1 m dBA
	Gen.	63	125	250	500	1000	2000	4000	8000		
L _{WA} to input [dBA]	75	34	47	59	70	69	72	64	56	55	65
L _{WA} to output [dBA]	71	34	43	54	67	64	67	64	55	51	61
L _{WA} surrounding [dBA]	67	37	44	54	65	60	63	55	41	47	57

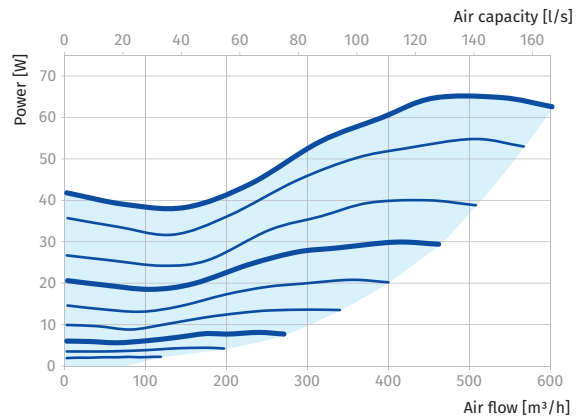
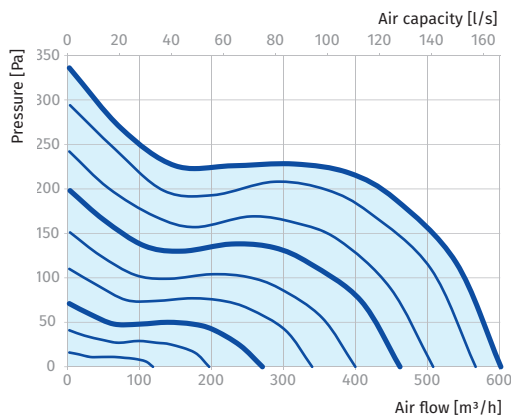

TURBO EC 200

Sound power level, A-weighted	Octave frequency bands [Hz]									LpA, 3 m dBA	LpA, 1 m dBA
	Gen.	63	125	250	500	1000	2000	4000	8000		
LWA to input [dBA]	76	36	45	57	70	69	72	69	59	56	65
LWA to output [dBA]	76	48	49	56	69	71	71	70	60	56	65
LWA surrounding [dBA]	69	35	42	54	64	65	65	58	43	49	59

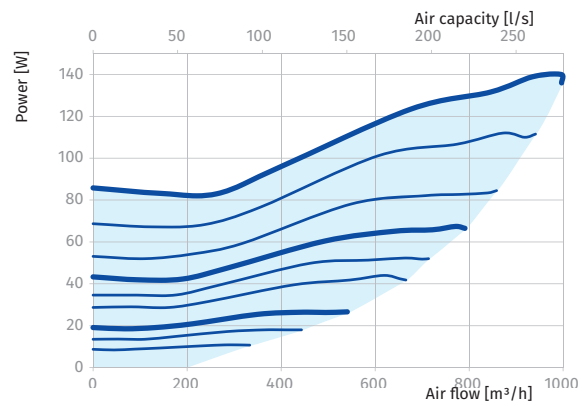
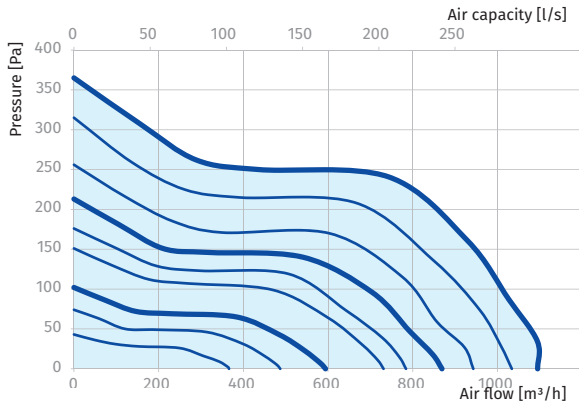

TURBO EC 250

Sound power level, A-weighted	Octave frequency bands [Hz]									LpA, 3 m dBA	LpA, 1 m dBA
	Gen.	63	125	250	500	1000	2000	4000	8000		
LWA to input [dBA]	81	43	51	64	77	77	77	69	62	61	71
LWA to output [dBA]	81	49	54	67	75	78	77	72	62	61	71
LWA surrounding [dBA]	73	53	49	56	66	71	68	55	43	53	63

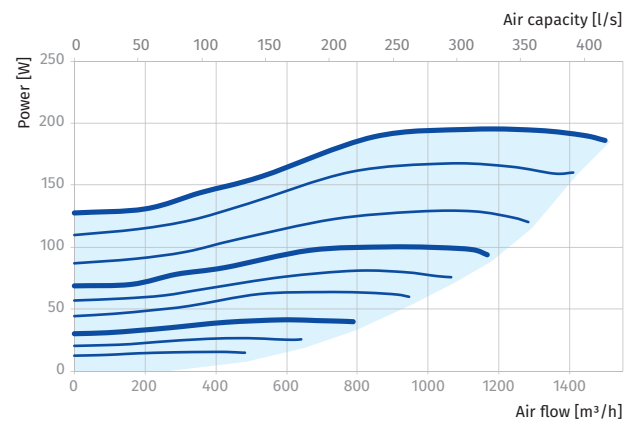
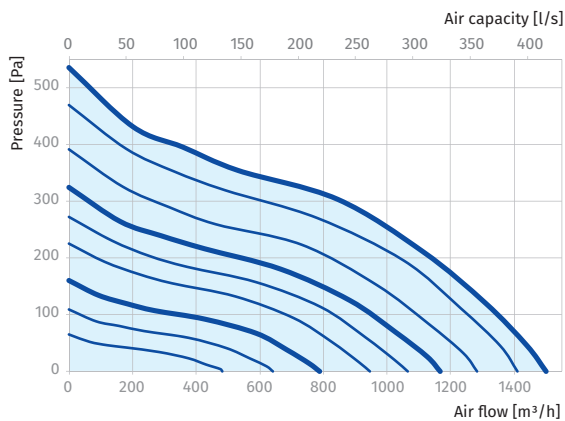

TURBO EC 315

Sound power level, A-weighted	Octave frequency bands [Hz]									LpA, 3 m dBA	LpA, 1 m dBA
	Gen.	63	125	250	500	1000	2000	4000	8000		
LWA to input [dBA]	81	42	54	64	74	78	75	70	63	61	70
LWA to output [dBA]	83	43	54	72	77	78	78	73	66	63	72
LWA surrounding [dBA]	75	37	48	60	68	73	68	60	48	55	65

