

TIMEGUARD®

Electronic Room Thermostat

Model: TRT030N



Installation & Operating Instructions

1. General Information

These instructions should be read carefully and retained for further reference and maintenance.

2. Safety

- Before installation or maintenance, ensure the mains supply to the thermostat is switched off and the circuit supply fuses are removed or the circuit breaker turned off.
- It is recommended that a qualified electrician is consulted or used for the installation of this thermostat and install in accordance with the current IEE wiring and Building Regulations.
- Check that the total load on the circuit including when this thermostat is fitted does not exceed the rating of the circuit cable, fuse or circuit breaker.
- To clean use a clean dry cloth only. Do not use any liquid cleaners.

3. Technical Specifications

- 230V AC 50 Hz
- This time switch is of Class II Construction and must not be earthed
- Switch Rating: 6(2)A
- Switch Type: Single pole, single throw (SPST)
- Connection Type: 3 wire
- Installation Type: Surface mount with wall plate
- Micro Disconnection: Type 1.B control action
- Operating Temperature Range: 0°C to +40°C
- Set Temperature Range: Minimum +5°C (frost setting) to maximum +30°C
- Temperature Swing Adjuster: +/- 0.5°C or 1.0°C set by DIP switch
- PID Adjustment: ON or OFF set by DIP switch

- Boiler Type Adjustment: 3CYC = Gas, 6CYC = Oil, set by DIP switch
- Output Light: Blue LED
- CE Compliant
- Dimensions (H x W x D): 86 x 88mm x 38mm

TRT030N Front View

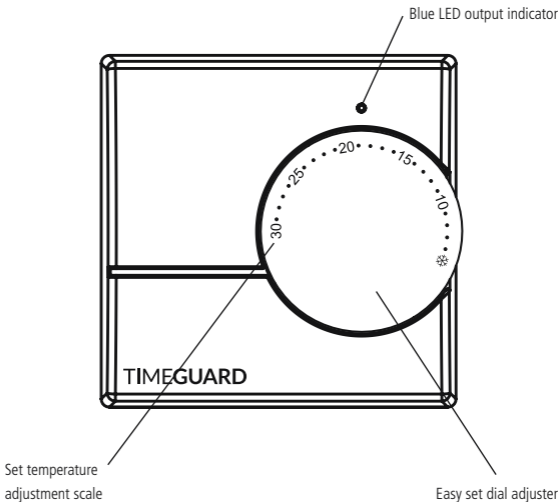

4. Siting

- The TRT030N must be sited where it will not be influenced by heat sources, for example above a radiator or a television or a refrigerator/freezer or in direct sunlight or subjected to draughts.
- The product requires air circulation, so do not position above or below shelving or other wall mounted obstacles.
- It should be mounted approximately 1.5 metres above floor level.

5. Installation

- 5.1 Ensure the mains supply is switched off and the circuit supply fuses are removed or the circuit breaker turned off.
- 5.2 Remove the wall plate from the unit, by undoing the retaining screws, and pivoting the bottom of the unit outwards. The TRT030N body can then be lifted off.
- 5.3 Mark the position of the mounting holes on the wall using the wall plate as a template. Drill out the mounting holes taking care to avoid any joists, electrical cables or water/gas pipes that may be hidden beneath the surface. Insert the rawl plugs into the holes.
- 5.4 Pass the 230V 50Hz mains supply and load cables through the opening of the wall plate. Allow sufficient excess cable to wire up the unit, but not too much to make it difficult to close the unit to the wall plate.
- 5.5 Fix the wall plate to the wall using the correct mounting screws for the rawl plugs installed. The retaining screws which secure the unit to the wall plate should be at the bottom.
- 5.6 Carefully remove the plastic terminal cover. Terminate the cables into the terminal block ensuring correct polarity is observed and that all bare conductors are sleeved (See section 6. Connection Diagram). Make sure that the curved washer grips the conductor. Reposition the plastic terminal cover and push into place.

- 5.7 To reinstall the unit onto the wall plate, first ensure the wall plate retaining screws are loosened enough to clear the TRT030N body, then engage the top of the TRT030N onto the wall plate retaining tabs, and push firmly downwards and then upwards. There will be some resistance from the terminals.
- 5.8 Once in place, secure with the retaining screws making sure not to over tighten.

TRT030N Wall Plate

Alternate mounting holes

Retaining tabs

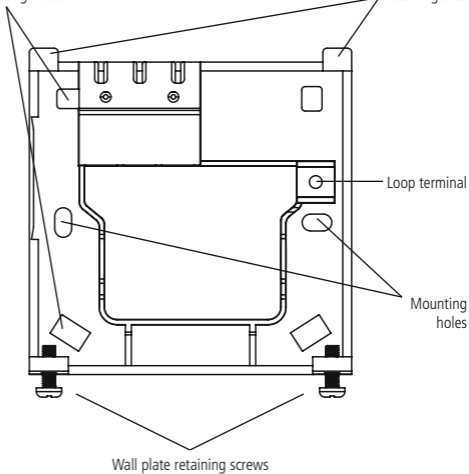

6. Connection Diagram

Connect the 230V 50Hz mains supply and load cables to the terminal block which are marked as follows;

- **Note: Check boiler instructions before connecting.**

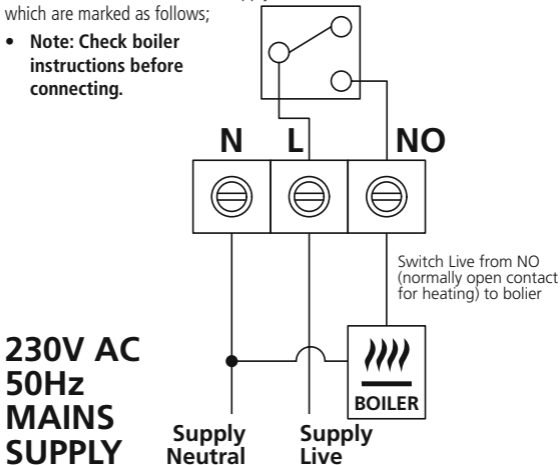

230V 50Hz Mains Supply

Live Supply (Brown or Red) to

L

Neutral Supply (Blue or Black) to

N

A 'Loop Terminal' is provided should a 3 core cable be used

Load (Boiler)

Switch Live (Brown or Red) to

NO

7. DIP Switch Settings

- The temperature swing can be adjusted between 0.5°C and 1.0°C by selecting the desired DIP switch position found on the rear of the unit. We suggest using 0.5°C position unless the boiler turns ON and OFF too rapidly.
- The PID 'Proportional-Integral-Derivative' can also be selected ON or OFF using the DIP switches on the rear of the unit. We suggest setting this to the ON position. As the room temperature approaches the set temperature, the thermostat will intermittently turn the heating ON and OFF, to help prevent temperature over-shoot.
- The boiler type can be set to either 3CYC (Gas) or 6CYC (Oil), using the DIP switches on the rear of the unit.

8. Operation

- Restore mains to the unit after making sure to check all system wiring is complete, and after you have selected the desired DIP switch settings.
- Use the dial adjuster to set the desired temperature.
- The Blue LED output indicator is lit when the room temperature is below the desired value, indicating that the thermostat is calling for heat from the boiler.
- Once the room reached the desired temperature the LED turns OFF and the TRT030N ceases to call for heat from the boiler.

3 Year Guarantee

In the unlikely event of this product becoming faulty due to defective material or manufacture within 3 years of the date of purchase, please return it to your supplier in the first year with proof of purchase and it will be replaced free of charge. For the second and third years or any difficulty in the first year telephone the helpline on 020 8450 0515.

Note: A proof of purchase is required in all cases. For all eligible replacements (where agreed by Timeguard) the customer is responsible for all shipping/postage charges outside of the UK. All shipping costs are to be paid in advance before a replacement is sent out.

If you experience problems, do not immediately return the unit to the store. Telephone the Timeguard Customer Helpline;

HELPLINE

020 8450 0515

or email helpline@timeguard.com

Qualified Customer Support Co-ordinators will be on-line to assist in resolving your query.



A **theben** Group Company

For a product brochure please contact:

Timeguard Limited.

Victory Park, 400 Edgware Road, London NW2 6ND

Sales Office: 020 8452 1112

or email csc@timeguard.com

www.timeguard.com

67.058.596 (Issue 1)