



Installation and Operating Instructions QuietAir 150mm Axial Fan



MODEL:QT 150T - Two Speed Fan (220/260m³/hr)
With Delay Start and Adjustable
Timer control



- Basic Switching with timer
- Low Energy
- Quiet
- Long Life
- Extra Safe
- Interval Timer

IP45  CE

Installation and Operating Instructions

CONTENTS

Chapter 1. GENERAL INSTALLATION AND OPERATION INSTRUCTIONS

- 1.0 Important Information
- 1.1 Warnings
- 1.2 Safety Instructions
- 1.3 Warranty claims – Disclaimer
- 1.4 Regulations - Guidelines
- 1.5 Transport
- 1.6 Acceptance of delivery
- 1.7 Storage
- 1.8 Operational area
- 1.9 Performance data
- 1.10 Noise data

Chapter 2. GENERAL NOTES

- 2.0 Qualification of staff
- 2.1 Touch protection
- 2.2 Motor protection

Chapter 3. SPECIFICATIONS / DIMENSIONS

- 3.0 Specifications
- 3.1 Product lifetime
- 3.2 Accessories
- 3.3 Dimensions

Chapter 4. FUNCTION

- 4.0 Function description

Chapter 5. CLEANING / DEINSTALLATION

- 5.0 Cleaning
- 5.1 Cover dismantling

Chapter 6. INSTALLATION

- 6.0 Scope of delivery / Mechanical installation
- 6.1 Preparation for wall mounting
- 6.2 Installation
- 6.3 Electrical installation
- 6.4 Cable connection
- 6.5 Mounting
- 6.6 Operation

Chapter 7. INSTALLER FUNCTION

- 7.0 Function description
- 7.1 Performance Overview
- 7.2 Schematic overview

Chapter 8. CARE AND MAINTENANCE

- 8.0 Care and maintenance
- 8.1 Decommissioning and disposal
- 8.2 Troubleshooting

CHAPTER 1

GENERAL SAFETY INSTRUCTIONS

1.0 Important information

To ensure the proper functioning and for your own safety, the manual should be read and observed.

This document is part of the product and should be available at all times to ensure the safe operation of the fan. All equipment-related safety regulations should be adhered to.

DANGER

1.1 Warnings

The adjacent symbols are safety warnings. To avoid any risk of injury and dangerous situations, all safety regulations (symbols) in this document should be strictly observed.

WARNING

CAUTION

DANGER

1.2 Safety Instructions

For use, connection and operation please refer to these instructions. If in doubt, contact the manufacturer for advice. Other information is relevant to standards and legislative texts.

⚠ For all work involving operation of the fan, general applicable safety and accident prevention regulations should be observed.

- **All electrical work and commissioning should be carried out by authorized and qualified electricians.**
- **Maintenance and installation work should be carried out by competent personnel.**
- **Before cleaning, maintenance and installation work or before opening the terminal compartment the following points must be observed:**
 - **Disconnect the fan from power supply (all-poles) and secure against restarting!**
 - **Wait until all rotating parts have stopped moving!**
 - **After rotating parts have stopped moving, waiting period of 3 min should be observed; dangerous voltages can occur by internal capacitors even after disconnection from the network!**
- **All equipment-related safety regulations should be observed! If necessary, further country-specific regulations should be complied with!**
- **Contact protection (or Protection against accidental contact) should be insured according to DIN EN 13857 (see Chapter 2.1)!**
Contact with rotating parts should be avoided.

- **Ensure a uniform inflow and free outlet!**
 - **During operation within a fire place in the ventilated room, sufficient air supply should be provided in all operating conditions (please contact chimney sweep).**
- Valid local regulations and laws should be observed!**

1.3 Warranty claims – Disclaimer

All versions of this manual should be observed; otherwise the guarantee will be annulled. The same applies to liability claims against Airflow Developments Limited. Any potential damages are not a subject of the guarantee. Changes and modifications to the product are not allowed and will result in a loss of conformity - in such case any warranty and liability will be excluded.

1.4 Regulations – Guidelines

The fan should be properly installed and used for its intended purpose. The product complies with the valid regulations and CE-guidelines at the time of its production.

1.5 Transport

The fan is factory-packed so that it is protected against normal transport loads. It is recommended to leave the fan in the manufacturer's original package.

1.6 Acceptance of delivery

A visual inspection upon delivery should be performed including damage and type accuracy check. In the event of there being any damage, the necessary notification of claim immediately has to be reported to the carrier. Any delay in complaint will result in a loss of benefit entitlement.

1.7 Storage

When storing for a long period of time, avoid harmful impacts by following these steps: protect the motor by dry, air and dustproof package (plastic bags with drying agent and moisture indicator). The product should be stored in a vibration-free and water-protected premise at a constant temperature ranging from -20 °C up to + 40 °C. In compliance to Chapter 8, when storing a product for more than three months (motor standstill), maintenance should be determined before commissioning. In case of transshipment (especially over longer distances: e.g. sea), the packaging has to be checked whether it is suitable for transport and on the route. Damages caused by improper transportation, storage or installation are not covered by the warranty.

1.8 Operational area

- Appropriate use:

QuietAir 150 fans are used to convey normal or slightly dusty (particles size < 10 µm), little aggressive and humid air, into moderate climate and suitable area of its performance curve (see Airflow sales documentation / Internet). Operation permitted only for fixed installation within buildings. Maximum permitted medium and ambient temperature is 40°C. QuietAir 150 fans conform to protection rating IP45, protection class II and according to VDE0100 part 701 can be installed in zones 1 and 2 of your wet room.

- Rationally foreseeable misuse

The fans are not suitable for use under difficult conditions such as high humidity, aggressive media, longer downtimes, strong pollution, and excessive workload due to climatic, technical or electronic influences. The same applies for the mobile use of this fan (cars, aircrafts, ships, etc.). To perform under these conditions please check with Airflow Developments Limited before installing.

- Prohibited use

Solids or solid impurities > 10 µm in transporting medium as well as liquids are not allowed. Transporting medium which are aggressive against the fan material as well as abrasive media is not allowed. Usage of the fan in an explosive environment is prohibited.

1.9 Performance data

The device type plate is binding for the electrical data; this should conform to the local supply network. On the test stand fan, performance complied with DIN EN ISO 5801.

1.10 Noise data

The noise data which relate to distances is valid under free flow conditions. After installation the sound pressure level can vary significantly from the catalog values since it strongly depends on the installation conditions, for instance the absorption capacity of the room, the room size etc.

CHAPTER 2

GENERAL NOTES

2.0 Qualification of staff

⚠ Maintenance and installation work must be carried out only by an approved electrician.

The QT150T should not to be used by children and persons with reduced physical, mental or sensory capacities, without proper practical experience or expertise, unless they are controlled or instructed on the product operation by the person(s) responsible for their safety. Children should not play with the device. Cleaning and maintenance must not be carried out by children without supervision.

DANGER

2.1 Touch protection

The QT150T is supplied with a standard suction side protective grid. Depending on the installation conditions protection against accidental contact on the discharge side may also be required. Appropriate protective grids are available as an accessory.
- According to the installation method (for instance installation in ventilation canals or covered aggregates) fans are already protected and in such cases they do not need a protective grid. It should be noted that the operator is responsible for compliance with the current requirements and is liable for accidents.

2.2 Motor protection

The QT150B has an energy-saving maintenance-free EC Motor with high efficiency. The motor is equipped with a thermal contact, wired in series, which automatically switches on/off after cooling.

If the motor is blocked there will be an attempt to restart it every 3 seconds.

To start the motor a certain rotor position is required. If it doesn't detect it, it outputs pulses to the rotor in order to reach this position. This may take a few seconds.

Installation and Operating Instructions

CHAPTER 3

SPECIFICATIONS/ DIMENSIONS QT150T

3.0 Specifications

Impeller – Ø	137	Electrical supply	NYM-0 3x1,5 mm ²
Alternating current		Degree of protection	IP 45 (jet-proof)
Voltage/frequency	230 V, 50Hz	Protection class	II
Power input (W)	10 / 6	Weight approx. kg	1.2
Rated current (mA)	100 / 70	Rotational speed	1900/1600
Flow volume (m ³ /h)	260 / 220	Shut down (min.)	6,10,15,21 (adjustable)
		Interval (H)	0,8,12,24 (adjustable)

3.1 Product lifetime

This unit is designed for a product life of at least 40.000 hours in Speed 1 mode with maximum power in the maximum permissible ambient temperature.

3.2 Accessories

9041315 2 Speed Switch

Order

3.3 Dimensions

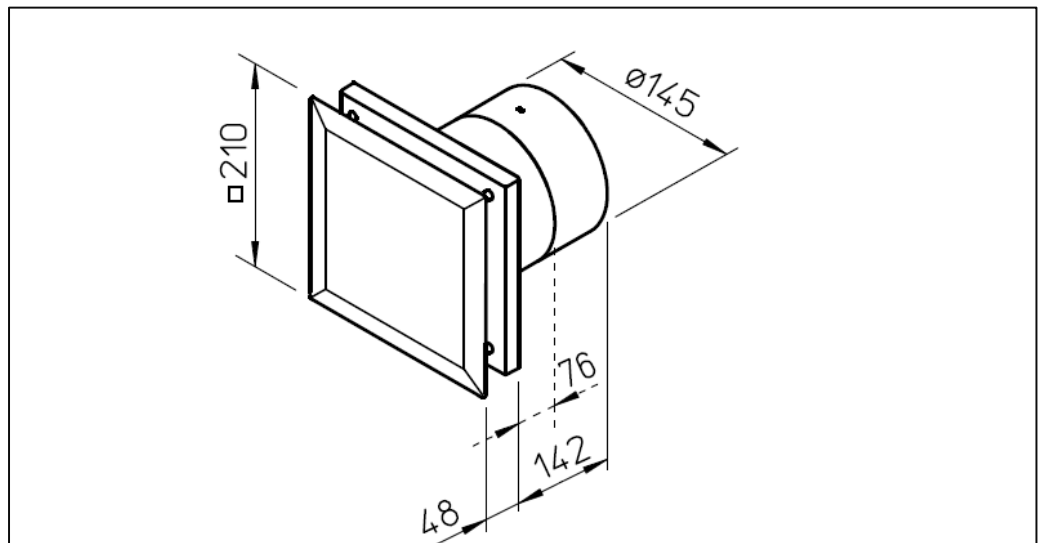

CHAPTER 4

4.0 Function description

FUNCTION

1. Switch-on delay

The fan turns on only after the set delay time (0, 45, 90, 120 sec.). By mutual activation the light function can be switched on for a short time without fan coming on stream. Turn-on delay performs only after coming to a complete stop of the fan. When switching between current stages – ignore applicable switch-on delay. By mutual activation of both stages, turn-on delay can be considered only when time function is activated on both stages.

2. Push button operation

If there is no switch-on delay (DIP 1 / 2 off / off) activated, then switch inputs 1 or 2 can be controlled by a push-button. For this relevant stage time function should be activated.

The button must be pressed for more than 0.5 seconds. As soon as the stage will be activated by the push-button, the corresponding stage will switch off itself at the end of the run on time.

3. Shut down

By switching off the current stage the fan will turn off only after the set lag time has elapsed. The length of the run on time can be adjusted (6, 10, 15, 21 minutes).

When switching between the stages, the run on time will be ignored. By mutual shut-down of the both stages, the run on time will be considered only when time function will be activated on both stages.

4. Intermittent operation

The fan can be set at adjustable intervals to perform automatically. The intervals can be adjusted (0, 8, 12, 24 hours). During the interval mode adjusted post-run time corresponds to the duration of the cycle. Intermittent operation starts after the last turn-off. The required ventilation is the overriding importance for the intermittent operation. In the interim required ventilation, started interval time will reset and restart after the shutdown.

CHAPTER 5

5.0 Cleaning

**CLEANING /
DISMANTLING**

DANGER

⚠ Safety instructions listed in Chapter 1.2 should be observed!

- Before cleaning always ensure that the fan is isolated from the power supply and secured against restarting!
- Clean cover, protective guard and visible housing parts (the external housing of the fan) with a damp cloth!
- Do not use any aggressive or paint solvent cleaning agents!
- High pressure cleaners or water sprays should not be used!

DANGER

5.1 Cover dismantling

1. Isolate the fan from the power supply and secure against restarting.
2. Pull the side pieces (cover plates) of the upper part of the housing outwards (see Fig 1/Fig 2) to un-latch it and upwards until the cover plate is opened.

Installation and Operating Instructions

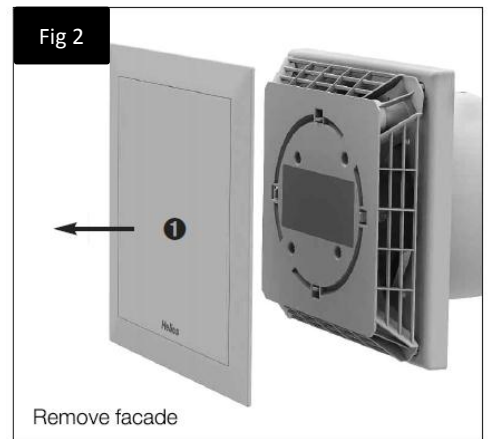

All of the following information and instructions are intended for use by authorized electricians.

CHAPTER 6
INSTALLATION

6.0 Scope of delivery / Mechanical Installation

A visual inspection upon delivery should be performed including a check to ensure all components are present. Take the unit out of the box immediately before installation in order to avoid possible damage and contamination during the transport as well as at the construction site.

Scope of delivery:

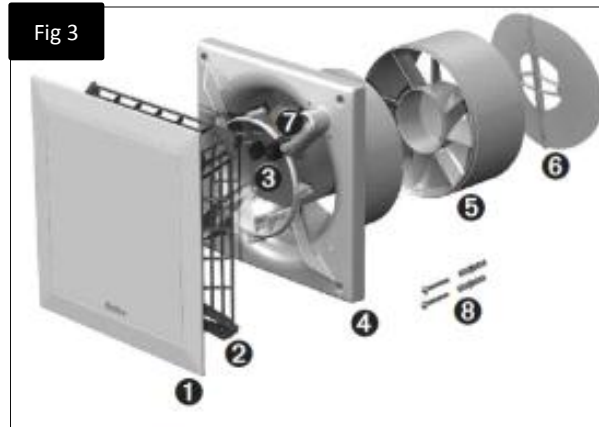

1. **Cover**
2. **Terminal compartment cover** incl. 4x fastening screws
3. **Control board**
4. **Plastic housing** with impeller
5. **Guide vane**, with limited mounting depth removable
6. **Backdraft shutter**, removable
7. **Cable support sleeve** x 2
8. **Mounting kit**
2x screws with plugs for a wall mounting
9. **Foam strips**

DANGER

6.1 Preparation for wall mounting

⚠ Safety instructions listed in Chapter 1.2 must be observed!

The fan is supplied as a complete unit, which is delivered ready for connection. The installation and set-up of the fan should be performed only after final cleaning to avoid damage and contamination of the ventilation unit.

After unpacking and before installation the following points must be checked:

- if any transport damage is noticed,
- broken or bent parts
- free rotation of the impeller

6.2 Installation

The QT150T is designed for direct wall mounting. The housing should not be deformed or warped during the installation. Choose a flat location for mounting. Fans can be heavy and are sometimes unwieldy. Proper precautions should be taken, to ensure the assembly is well supported and stable before lifting into position. Fans should be mounted on a strong and stable surface using appropriate fasteners.

1. Cable outlet in the wall

- Position of the cable outlet in the dark area is variable (Fig 4).
- Clearance to the pipe centre depending on the cable outlet $r = 83 \text{ mm}$ (at a variable position from 0 up to 360°).
- For an easy assembly, it is recommended to place outlet as shown in fig 5 (90° rotatable). The optimal position is at 45° when the cable outlet placed directly at the position of the cable support sleeve.
- QT150T Pipe inner diameter = $\varnothing 150 \text{ mm}$
- Clearance to room corners: at least 130 mm from the pipe centre
- During the wiring the side recess for the cable entry in the housing (Fig 7, Position1) should be broken out.

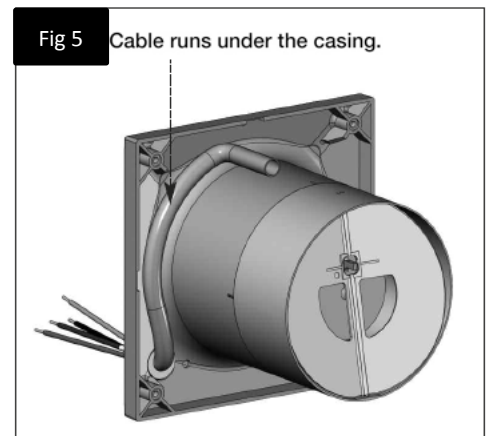
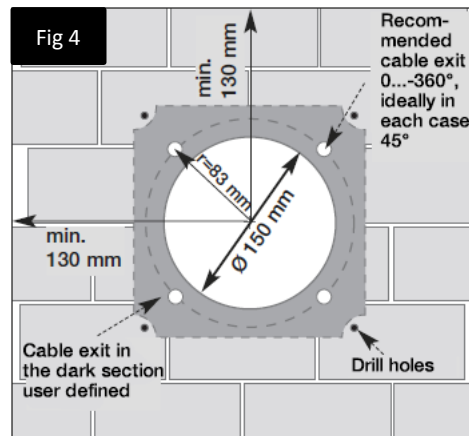

2. Boreholes

Position the housing, then mark and drill the holes and mount it with at least two fastening screws and wall plugs.

3. Backdraft shutter and guide vane

- If required backdraft shutter (included in delivery) can be installed behind the guide vane (Fig 6).
- During the housing installation, the guide vane should be mounted vertically.
- Before final assembly stick on the rubber foam (included in delivery) (Fig 6).

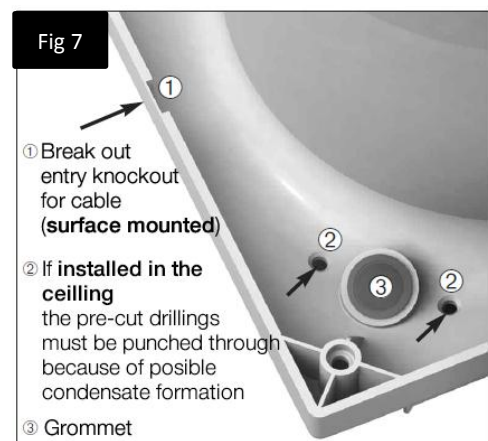
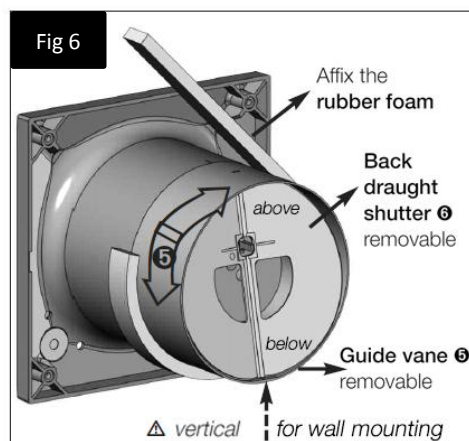

DANGER

6.3

Electrical installation/Commissioning

⚠ Safety instructions listed in Chapter 1.2 should be observed

- **All electrical installations to be carried out by an approved electrician in accordance with presented manual and wiring diagrams.**
- **Fan should be fitted with a 3A fuse at all times.**
- **The relevant standards, safety regulations (for instance DIN VDE 0100) and technical connection regulations of the energy supply company should be observed!**
- **An all-pole mains switch/isolation switch, with at least a 3 mm contact opening (VDE 0700 T1 7.12.2 / EN 60335-1) is mandatory by law!**
- **Network configuration, voltage and frequency of the power source should match the information on the rating plate.**

6.4 Cable connection

- Use NYM cable with a customary maximum diameter of 11 mm.
- Remove cable sheath to a length of 135 mm. Strip back each wire's insulation by about 8 mm.
- Carefully slide cable through the grommet.
- The wiring diagram (SS-1080) should always be used to ensure proper wire placement.
- Check sealing of the connection cables and cable wires clamp.
- If mounted at the inlet spout the sheathed cable does not enclose evenly, the spout should be additionally sealed with silicone. Otherwise, the IP protection will be compromised.
- The connection cable should be positioned in such a way that in case of water entering, water may not penetrate along the cable. Cables should be laid in such a way that they do not run over sharp edges.
- Check the fan according to the intended use.
- Supply voltage should match the name plate data.
- Ensure secure mounting and proper electrical installation of the device.
- Check the rotation of the impeller.
- All parts of the fan, especially screws and protective grid must be checked for tightness. Do not mislay the screws included with the unit!
- **Ensure that the necessary protective guard is installed, as the unit cannot be operated without it.**
- During the trial run the fan should be checked for vibrations and noise.
- Power consumption should match the name plate data.

DANGER

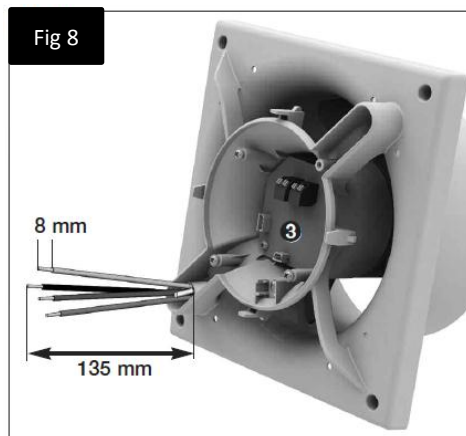

- Length of individual wires 135 mm
- Wire stripping 8 mm
- Strip the non-metallic sheathed cable which sits flush with cable duct

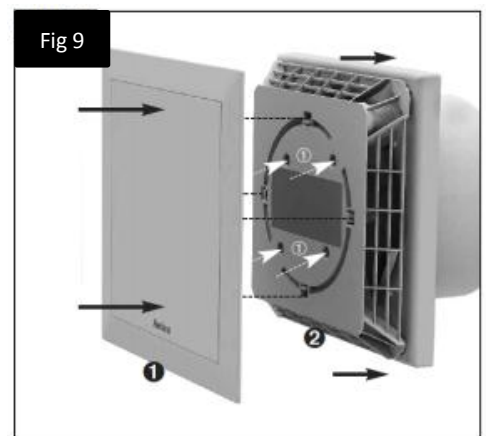

1. Terminal compartment cover put on the plastic housing and screw tight
2. Fit and snap in the cover

6.5 Mounting

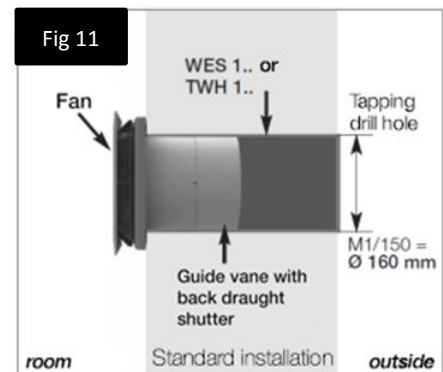
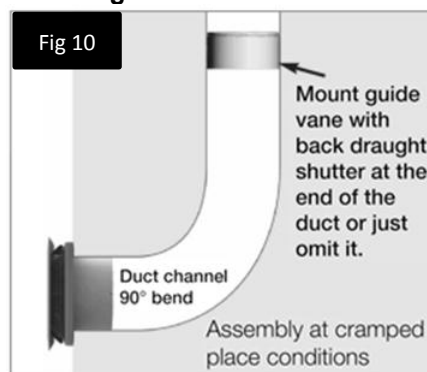

DANGER

6.6 Operation

⚠ Safety instructions listed in Chapter 1.2 must be observed!

- To guarantee the proper function of the fan, the following should be checked regularly:
- Appearance of dust or dirt in the housing (on the motor and impeller)
 - Free rotation of the impeller
 - Appearance of excessive vibration and noise

In case of problems with one of the points listed above maintenance should be carried out according to the instructions in Chapter 8.

CHAPTER 7

7.0 Function description QT150T (Timer model)

**INSTALLER
FUNCTION**

1. Terminal assignment

- Terminal N / L

Terminal N and L have to be connected to the 230V operating voltage.

- Terminal 1

Terminal 1 activates the low stage.

- Terminal 2

Terminal 2 activates the high stage.

- Both terminals

The last specification conducts independently with or without timer.

By simultaneous operation of two stages - conducts stage 2.

A change of the DIP switch settings must be carried out only by authorized and qualified electricians. The device must be disconnected (all-pole) from power supply. A change of the DIP switch is allowed only after switching off mains supply.

2. Activation of the timer function

Timer function (turn-on delay, run on time) can be activated at the requested stage or deactivated via 7 and 8 DIP switches.

3. Switch-on delay

Turn-on delay can be set via 1 and 2 DIP switches. The fan starts automatically only after the set delay time has expired. By mutual activation the light function can be switched on for a short time without fan coming on stream. Turn-on delay performs only after coming to a complete stop of the fan. When switching between current stages – ignore applicable switch-on delay. By mutual activation of both stages, turn-on delay can be considered only when DIP switches 7 and 8 are activated.

4. Push-button operation

If there is no switch-on delay (DIP 1 / 2 off / off) activated, then switch inputs 1 or 2 can be controlled by a push-button. For this relevant stage time function should be activated.

The button must be pressed for more than 0.5 seconds. As soon as the stage will be activated by the push-button, the corresponding stage will switch off itself at the end of the run on time.

5. Shut-down

By switching off the current stage the fan will turn off only after the set lag time has elapsed. The length of the run on time can be adjusted via 3 and 4 DIP switches.

When switching between the stages, the run on time will be ignored. By mutual shut-down of the both stages, the run on time will be considered only when 7 and 8 DIP switches are activated.

6. Intermittent operation

The fan can be set at adjustable intervals to perform automatically. The intervals can be set via 5 and 6 DIP switches. During the interval mode adjusted run on time corresponds to the duration of the cycle. Intermittent operation starts after the last turn-off. The required ventilation is the overriding importance for the intermittent operation. In the interim required ventilation, started interval time will reset and restart after the shutdown.

The speed assignment will be set via 7 and 8 DIP switches (see table below):

DIP switch		Time function	Interval
7	8		
off	off	no time	speed level 1
on	off	time at speed level 1	speed level 1
off	on	time at speed level 2	speed level 2
on	on	time at both speeds	speed level 2

7.1 Function test – Test mode:

Upon connection of the operating voltage the fan is for 1 min in a test mode (prerequisite: DIP switches factory settings, see SS-1081). In this case switch on delay and run on time functions are within the first minute deactivated.

7.2 Schematic overview for QT150T (Timer model)

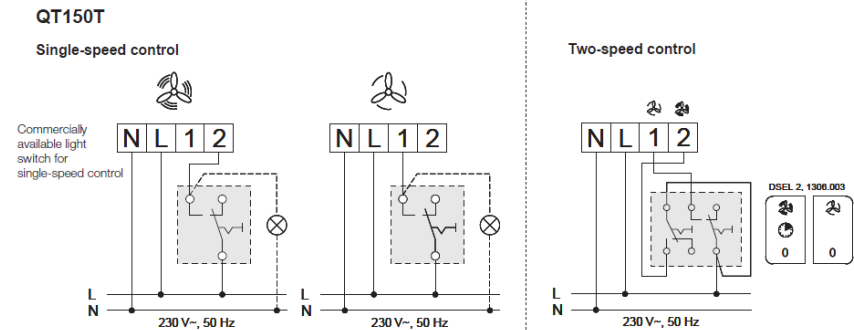

		DIP-switch							
		1	2	3	4	5	6	7	8
Delayed start	0 sec.	off	off	---	---	---	---	---	---
	45 sec.	on	off	---	---	---	---	---	---
	90 sec.	off	on	---	---	---	---	---	---
	120 sec.	on	on	---	---	---	---	---	---
Run on time / Running time	6 min.	---	---	off	off	---	---	---	---
	10 min.	---	---	on	off	---	---	---	---
	15 min.	---	---	off	on	---	---	---	---
Intervall time Running time = Run on time	21 min.	---	---	on	on	---	---	---	---
	0 h.	---	---	---	---	off	off	---	---
	8 h.	---	---	---	---	on	off	---	---
Level assignment for time function	12 h.	---	---	---	---	off	on	---	---
	24 h.	---	---	---	---	on	on	---	---
	no time set	---	---	---	---	---	---	off	off
	time on level 1	---	---	---	---	---	---	on	off
Factory setting	time on level 2	---	---	---	---	---	---	off	on
	time on both levels	---	---	---	---	---	---	on	on
	Interval	---	---	---	---	---	---	---	high level
		on	on	off	on	off	off	off	on

85336 002 SS-1081,1 23.09.14

CHAPTER 8

8.0 Care and maintenance

**CARE AND
MAINTENANCE**

DANGER

⚠ Safety instructions listed in Chapter 1.2 must be observed!

- **Prior to all work always ensure that the fan unit is isolated from the power supply and secured against restarting!**
- In principle the devices are maintenance-free; the unit is not user serviceable. Nevertheless all necessary maintenance work must be carried out by qualified electricians!
- Excessive deposits of dirt, dust, fats etc. on the impeller, motor, protective grids and especially between housing and impeller are not allowed; as it can lead to heavy imbalance in the impeller, overheat the motor or even block the impeller. In those instances the device has to be cleaned.
- In case of no longer use the unit must be serviced before operation.

Should be examined:

- Secure mounting of the fan / replace if in doubt
- Remove contaminant deposits
- Mechanical damage, shut down the device, replace damage parts
- Firm seating of bolt connections, loosen screws
- Housing quality (cracks, brittleness of the plastic)
- Overrunning of the impeller, the impeller doesn't run freely, note possible causes of failure in Chapter 8.1
- Bearing noise
- Vibrations – see Chapter 8.1
- Power consumption according to the specifications on the type plate – see Chapter 8.1

DANGER

8.1 Decommissioning and disposal

Safety instructions listed in Chapter 1.2 should be observed!

During transportation safety instructions listed in Chapter 1.4 should be observed.



CAUTION

Parts and components of the fan which have reached the end of their lifespan, for instance because of the wear and tear, corrosion, mechanical loading, fatigue and/or other effects that could not be directly discerned, should be disposed in accordance with local and international laws and regulations. The same applies to auxiliary materials such as oils, greases or other substances. The conscious or unconscious re-use of used components such as impellers, bearings, belts, etc. may endanger persons, the environment as well as the equipment itself. Relevant local operating regulations should be observed and applied.

8.2 Troubleshooting

⚠ Safety instructions listed in Chapter 1.2 should be observed!

Attention: If the impeller or motor is blocked allow 3 seconds for the restart interval.

	Causes	Solution
Fan doesn't start	- No voltage	Mains voltage check Check connection according to wiring diagram
	- Blocked impeller	Clear blockage, clean or replace
	- Blocked motor	Contact Airflow Technical Support
Fuse Tripping	- Winding is short-circuiting the motor	Contact Airflow Technical Support
	- Damaged cable or connector	Replace parts, if necessary replace motor (Contact Airflow Technical Support)
	- Connected incorrectly	Check the connection, modify
Vibrations	- Contamination	Clean
	- Mounting vibrancy	Check mounting, repair
Abnormal noises	- Grinding impeller	Clean impeller, replace
	- Bearing damages	Contact Airflow Technical Support
	- Mechanical damages	Perform maintenance
Fan doesn't perform properly	- Insufficient air flow	Check inflow and outflow / keep clear
	- Wrong voltage	Check connection / modify
	- Contamination	Clean
	- Insufficient back-flow	Extend back-flow

Installation and Operating Instructions

Warranty:

Applicable to units installed and used in the United Kingdom. Airflow's Warranty covers the QuietAir fan for TWO years. The Warranty can be upgraded to THREE years from date of purchase against faulty material or workmanship by registering on our web site at www.airflow.com. The Warranty covers the product only and not the installation cost.

In the event of any defective parts being found, Airflow Developments Ltd reserve the right to repair or at our discretion replace without charge provided that the unit

1. Has been installed and used in accordance with the fitting and wiring instructions supplied with each unit
2. Has not been connected to an unsuitable electrical supply
3. Has not been subjected to issue, neglect or damage.
4. Has not been modified or repaired by any person not authorised by Airflow Developments Ltd.
5. Has been installed in accordance with latest Building Regulations and IEE wiring regulations.

Airflow Developments shall not be liable for any loss, injury or other consequential damage, in the event of a failure of the equipment or arising from, or in connection with, the equipment excepting only that nothing in this condition shall be construed as to exclude or restrict liability for negligence.

This warranty does not in any way affect any statutory or other consumer rights.



Airflow Developments Limited
Aidelle House, Lancaster Road, Cressex Business Park
High Wycombe, Buckinghamshire
HP12 3QP, United Kingdom

E-mail: info@airflow.com

Telephone: +44 (0) 1494 525252

Facsimile: +44 (0) 1494 461073

airflow.com

Addendum – 10/2016

The Building Regulations 2010, Statutory Instrument Part 9, paragraph 42, imposes a requirement that testing and reporting of mechanical ventilation performance is conducted in accordance with an approved procedure.

Compliance with this requirement by an assessed and registered 'Competent Person' should follow a 'Best Practice' process and adopt air flow measurement, Method A – The Unconditional Method – using a suitable UKAS certified measuring instrument. Generically referred to as a 'Zero Pressure Air Flow Meter' or 'Powered Flow Meter'.

Further information on this method is detailed in NHBC Building Regulations Guidance Note G272a 10/13 and BSRIA 'A Guide to Measuring air flow rates' document BG46/2015