

Passiv+ 200

Heat Recovery Unit

Technical Features

- Ultra slim-line construction.
- Passivhaus certificate.
- Low acoustic sound level.
- Equipped as standard with automatic summer bypass.
- High performance EC Motors.
- Intelligent frost protection ensures that the unit continues to operate optimally even at low temperatures.
- 99% Recyclable Materials.



Air flow:
Up to 56 l/s (200m³/hr)



Heat Recovery Efficiency:
From 86%



Specific Fan Power (SFP)
Down to 0.61 w/l/s.



Sound Pressure Level
Down to 33dB(A)



Benefits and Features

- Multi angle duct connections.
- Double rotating condensation drain.
- Easy fit anti-vibration mounts included as standard.
- Ultra slim 210mm.
- Vertical or Horizontal installation.
- Perfectly flat installation.
- Dual handed unit - one unit, L or R handing.
- Intelligent By-pass.

General Technical Data

Parameters	Passiv+ 200
Voltage [V/50-60 Hz]	230V - 50Hz
Power [W]	82W
Current [A]	0.34
Maximum air flow l/s (m ³ /h)	55.5 (200)
Sound pressure level at 3 m [dBA]	33dB(A)
Transported air temperature [°C]	-25°C - +40°C
Casing material	EPP Expanded Polypropylene
Extract filter	G4
Supply filter	F7
Connected air duct diameter [mm]	160mm
Weight [kg]	24kg
Heat recovery efficiency [%]	86%
Heat exchanger type	Cross Flow
Heat exchanger material	Aluminium
Mounting type	Horizontal and Vertical

Passiv+ 200

Heat Recovery Unit

Technical Specifications

Blauberg PASSIV+ 200					
Supply voltage	230V/ 50 Hz				
Ingress protection	IP 40				
Dimensions (L x H x D)	1000 x 600 x 210 mm				
Duct connection diameter	Ø 160				
Diameter of condensate connection	1/2"				
Weight	24 Kg				
Filter class	Coarse 65% (G4)				
Fan position (standard)					Boost mode
Wireless smart multi-controller (optional)	0	1	2	3	Maximum
Ventilation flow (m3/h)	30	75	100	150	200

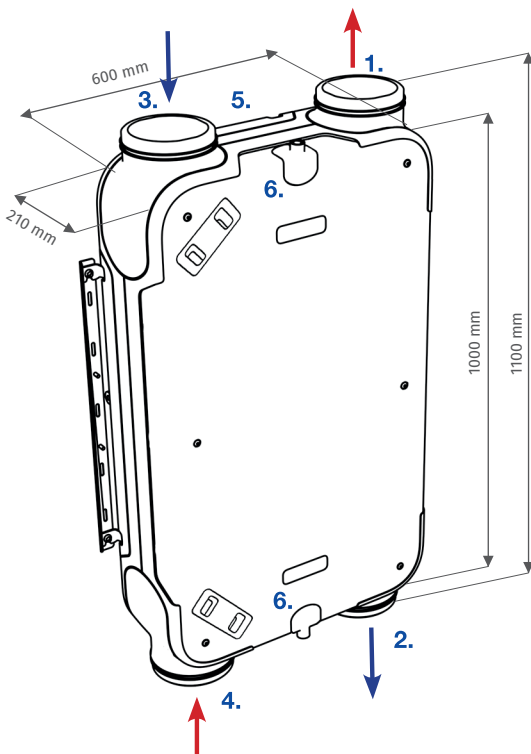

STANDARD VERSION LEGEND*

1	Extraction of stale air
2	Supply fresh (warmed) air into dwelling
3	Fresh air input from outside
4	Extraction of stale air from inside the dwelling
5	Electrical connection
6	Condensate drain connection

*Airflow model right version

Passiv+ 200

Heat Recovery Unit

Heat and Humidity Regeneration

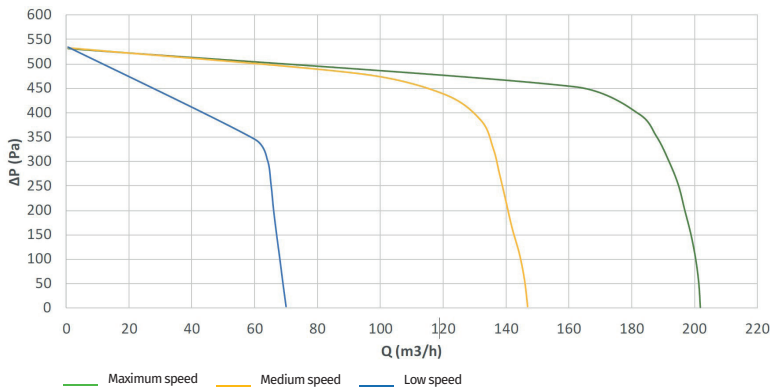
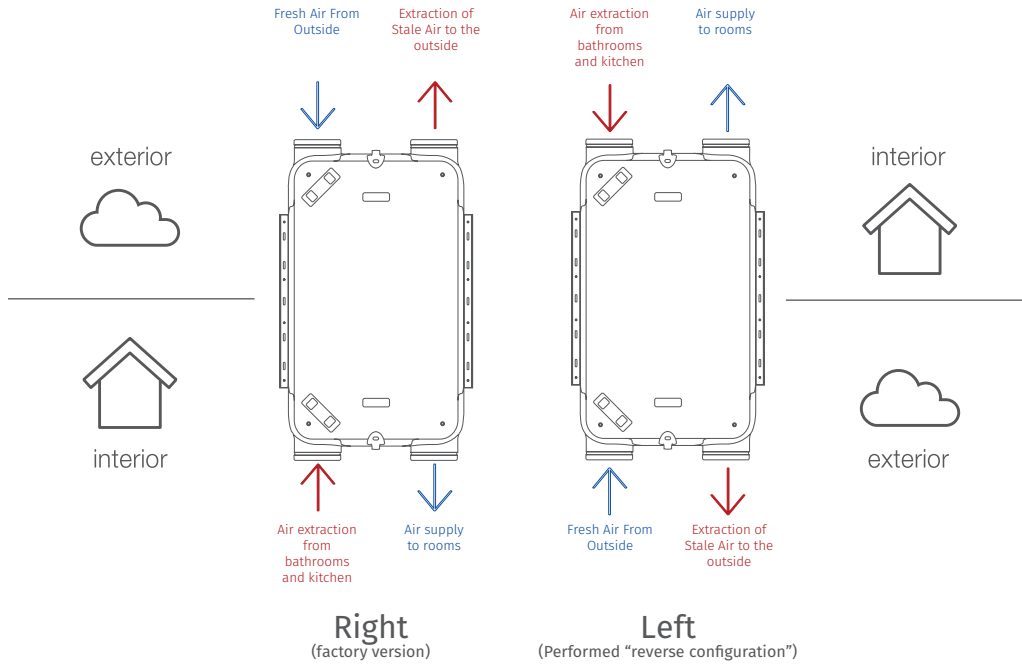

Acoustic level Blauberg PASSIV+ 200						
Ventilation Flow (m³/h)	75	125	150	200	200	
Static pressure (Pa)	25	50	50	100	150	200
Case Breakout (dB(A))	33	42	44	46	51	56
Extract duct (dB(A))	34	43	45	48	50	57
Supply duct (dB(A))	46	51	59	62	65	66

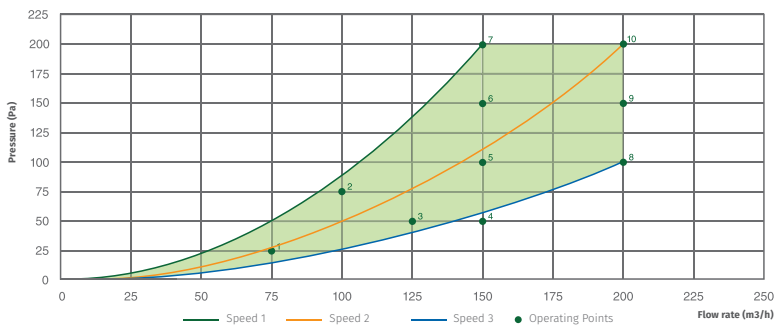

Operating Points	Flow (M³/H)	Pressure (Pa)	Power (W)	Sfp (W/L/S)
1	75	25	12.61	0.61
2	100	75	25.31	0.91
3	125	50	29.16	0.84
4	150	50	39.20	0.94
5	150	100	49.65	1.19
6	150	150	60.92	1.46
7	150	200	72.60	1.74
8	200	100	81.33	1.46
9	200	150	93.10	1.68
10	200	200	106.48	1.92

Smart Connectivity

You can turn the house into a smart home (optional) from different gateways available, as well as connect the unit to the mobile device with the Blauberg APP EVO.

- MODBUS - RS485
- KNX - Evo Connect
- Ethernet bridge (specifies Blauberg APP EVO connection)

MODBUS - RS485

- » The Blauberg RS485 (PASSIVFRS485) connects to the building management system (BMS) via cabling, in Modbus language for both reading and writing data. It collects information from Blauberg PASSIV+ 200 units and compatible wireless sensors and controls (PASSIVCTRL, PASSIVCO2 and PASSIVHR) that are linked to this ventilation unit.

KNX - Evo Connect

- » The EVO CONNECT (PASSIVCONNECT) device is a modbus / knx converter, it needs to be connected by cable to the gateway (Modbus - RS485) to translate the information collected by the gateway (Modbus - RS485) and send it by wiring to the BMS. Collects information from Blauberg PASSIV+ 200 units and compatible wireless sensors and controllers (PASSIVCTRL, PASSIVCO2 and PASSIVHR) that are linked to this unit. ventilation.
- » The Evo Connect requires a 24V power supply for proper operation.

Ethernet Bridge - Blauberg App EVO

Thanks to the intelligent control system, online monitoring of the most important elements is achieved, enabling the control and monitoring of the indoor air quality of the house through the Blauberg APP EVO.

- Control and regulation of unit speeds.
- Monitoring of CO2 and relative humidity of the house.
- » The Blauberg PASSIV+ 200 unit collects information from the various compatible wireless sensors and controls (PASSIVCTRL, PASSIVCO2 and PASSIVHR) via radio frequency.
- » The information is sent to the Ethernet gateway (Bridge Ethernet - PASSIVRFETH), whose device must be connected by cable to the modem of internet connection of the house, transferring the collected data to the "cloud" to give access and monitoring of the data through the Blauberg APP EVO.