

Niteflood® LED Floodlights

Installation guide for LED Floodlights

JCC | a **LEVITON** company

Warnings & Cautions

- To avoid electric shock, serious injury or property damage, isolate power before installing, removing or servicing the product.
- It is recommended that luminaires are installed by a qualified electrician to ensure the installation complies with the local current wiring regulations.
- Any broken or damaged parts should be replaced as soon as possible.
- JCC will not accept responsibility for claims arising from sub-standard installations; which will void the warranty.
- These products are designed for connection to a 220-240V~ 50/60Hz.
- The light source of this luminaire is not replaceable: When the light source reaches the end of its life, the whole of the luminaire must be replaced.
- It may be necessary to upgrade your MCBs to allow for increased inrush current.
- Terminal block not included. Installation may require advice from a qualified person.
- Do not install in areas that are exposed to continual running water or prone to flooding.
- Ensure that the mounting surface is both flat and stable.

INSTALLATION

ENGLISH

Specifications Colour temp: 4000K Ra: 83 Beam angle: 100°

Total circuit wattage	Lumens	LpcW
10W	1000	100
20W	2100	105
30W	3200	107
50W	5600	112

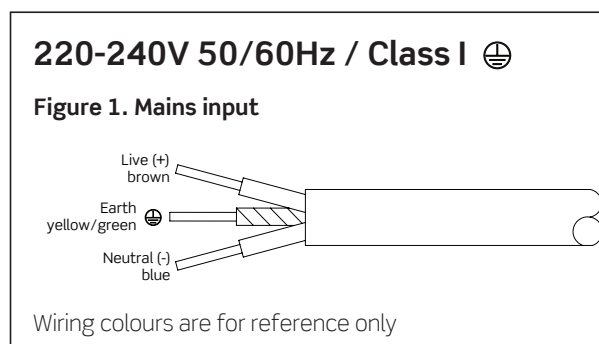

Terminal block must comply to EN 60998-2-1

Available finishes: Black or White

- Read instructions and check that you have all of the tools and accessories required to complete the installation correctly. Isolate power supply before starting the installation.

Installation procedure

1. Prepare the mains input cable for termination. Note that this product is class I and as such must be fitted with an earth connection.
2. Drill mounting holes and insert suitable wall plugs.
3. Rotate fitting to access screw mounting points on the bracket and secure using suitable fixings.
4. Terminate input wiring to the fitting as per Fig. 1 to the left using a suitable IP rated connector.
5. Check seals, gaskets and the cable gland integrity before testing the luminaire.
6. Turn on power supply and test for correct operation.

General Maintenance Requirements

This product has no user servicable parts. JCC Lighting Products would recommend that the following maintenance is performed in order to prolong the life of this product: Clean with a damp cloth and dry with a lint free cloth or kitchen towel. Do not use abrasive cleaners.

Important warranty information

This product is supported by a 2-year standard warranty which will extend to 3 years if registered within the first year of purchase. Please register at jcc.co.uk/warranty - Terms and conditions apply.

The installer will be asked to provide the following information, which is detailed on a label attached to the luminaire's chassis: Product Code/Date Code.

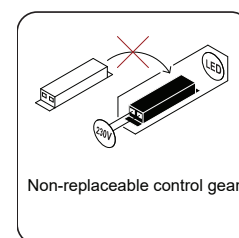
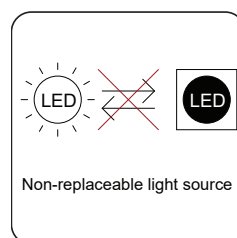

CE UK CA RoHS Compliant IP65 **jcc.co.uk**

ISO9001 - 2015 - Registered Firm Certificate No. GB 1552

JCC Lighting Products Ltd. Lux Park, Chichester Business Park, City Fields Way, Tangmere, Chichester, West Sussex, PO20 2FT

Technical Support: +44(0)1243 838986 Customer Services: +44(0)1243 838999

V1_AUG_2022_RS

Profile & Dimensions

All dimensions in millimetres

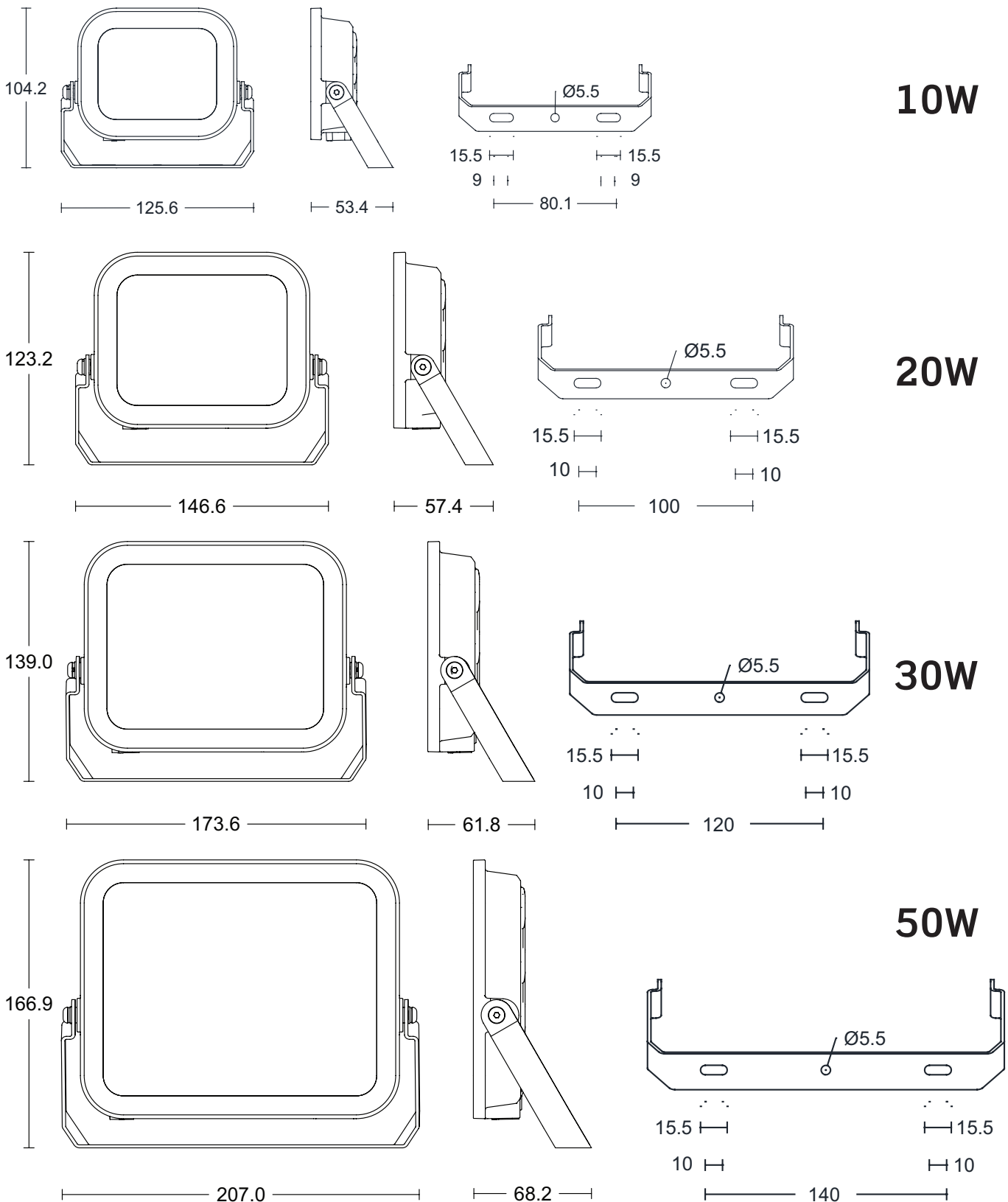

Important warranty information

This product is supported by a 2-year standard warranty which will extend to 3 years if registered within the first year of purchase. Please register at jcc.co.uk/warranty - Terms and conditions apply.

The installer will be asked to provide the following information, which is detailed on a label attached to the luminaire's chassis: Product Code/Date Code.