

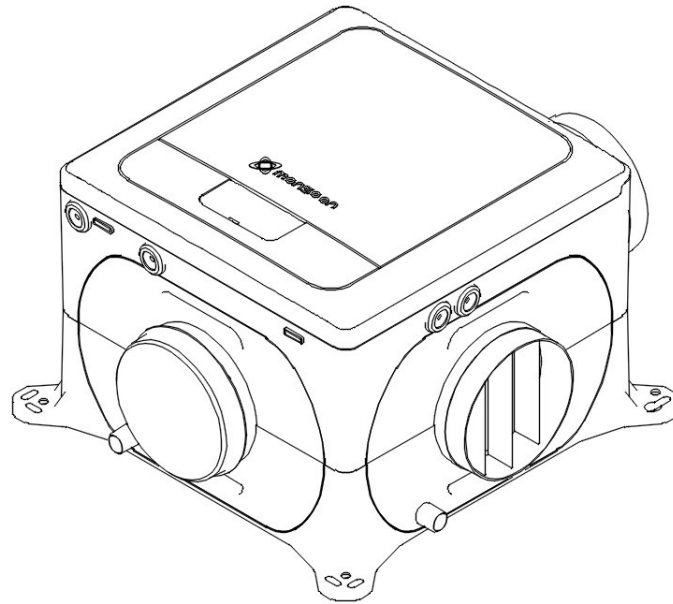

Installation & Commissioning Instructions



MON-MEYDC400

MON-MEYDCH400

Multi Room Unit

**Continuous Running Mechanical
Extract Ventilation**

220-240V~50Hz

**PLEASE READ INSTRUCTIONS IN CONJUNCTION WITH THE ILLUSTRATIONS.
PLEASE SAVE THESE INSTRUCTIONS**

IPX2
CE
UK
CA

Installation and Wiring Instructions for the Multi Room Extract Units.



IMPORTANT: READ THESE INSTRUCTIONS BEFORE COMMENCING THE INSTALLATION

- Do not install this product in areas where the following may be present or occur:
 - Excessive oil or a grease laden atmosphere.
 - Corrosive or flammable gases, liquids or vapours.
 - Subject to direct water spray from hoses.
 - Ambient temperatures higher than 40°C and lower than -20°C.
 - Possible obstructions that may hinder access to or removal of the unit.
- All wiring must be in accordance with the current IEE wiring regulations BS7671, or appropriate standards of your country. Installation should be inspected and tested by a suitably qualified person after completion.
- Ensure the mains supply (voltage, frequency and phase) complies with the rating label.
- The unit should be provided with a local double pole fused spur fitted with a 3A fuse having a contact separation of at least 3mm.
- This appliance incorporates an earth connection for functional purposes only
- Precautions must be taken to avoid the back-flow of gases into the building from the open flue of gas or other fuel-burning appliances.
- This appliance is not intended for use by persons (including children) with reduced physical, sensory or mental capabilities, or lack of experience and knowledge, unless they have been given supervision or instruction concerning use of the appliance by a person responsible for their safety.
- Young children should be supervised to ensure that they do not play with the appliance.
- Cleaning and user maintenance shall not be made by children
- The installer is responsible for the installation and electrical connection of the unit on site. It is the responsibility of the installer to ensure that the equipment is safely and securely installed and left only when mechanically and electrically safe.
- All regulations and requirements must be strictly followed to prevent hazards to life and property, both during and after installation, and during any subsequent servicing and maintenance.
- Certain applications may require the installation of sound attenuation to achieve the sound levels required.
- The unit must not be connected directly to a tumble drier.
- The exhaust grille should be located at least 600mm away from any flue outlet.
- This product and associated duct installation should be carried out in accordance with the Domestic Ventilation Compliance Guide.

INTRODUCTORY NOTES

The MEV units are designed for simultaneous extract ventilation of multiple areas such as bathrooms, kitchens and toilets. The units use a highly efficient backward curved centrifugal motor impeller set and are designed for continuous 24-hour use.

Depending on the model, they feature either 3 or 4 settable speeds and can be configured to change speed based on a wide range of sensor or control inputs as depicted below

Model	Speeds	Max airflow m ³ /hr (0Pa)	Switched Live Input (LS)	RS485 Connectivity	Analogue Input 0-10V	Digital Input	Humidity Sensor	CO2 Sensor	Wireless Receiver
MON-MEVDC400	3	430	Yes	No	Yes	Yes	No	No	No
MON-MEVDCH400	3	430	Yes	No	Yes	Yes	Yes	No	No

The units can be precisely programmed to determine how they respond to changes in sensor values or the status of the various signal inputs. The units will run at a Normal flowrate until a sensor or input change causes it to change speed. In the case of the Switched Live and Digital inputs the units will perform a step change in speed to the appropriate new level. In the case of the Analogue inputs, Humidity Sensor and CO2 sensor the unit can be programmed to give a proportional response to the change in conditions.

INSTALLATION

Position the unit, taking into consideration the position of the rooms to be ventilated, the exhaust position and the electrical services. Ensure there is adequate access for installation and maintenance.

If the unit is sited in the heated void of the dwelling a condensate drain should not be necessary. When sited in a cold loft, consideration should be given to fitment of a condensate drain. Alternatively the unit and ducting can be externally insulated to minimize condensation within the units housing.

To reduce the system resistance in your duct system, and therefore lower the speed, power consumption and noise of the fan, follow these guidelines:

- 1.1. Keep the length of duct runs to a minimum, particularly the exhaust duct run.
- 1.2. If you need to use flexible ducting, make sure that it is fully extended and not crushed, sagging or torn.
- 1.3. Try to minimize the use of diffusers/valves by having similar length duct runs to the inlets.
- 1.4. The bend radius (measured to the inside of the bend), should be at least 1x the duct diameter.
- 1.5. Avoid having any bends, filters or other obstructions within 250mm of the fan inlets and outlet.

Securely mount the unit through the mounting holes on the casing using appropriate fixings for the mounting substrate. Anti-vibration mounts; acoustic mat or rubber bushes can also be used.

Fixings (not supplied) to be capable of securing 4 x the weight of the unit. Unit weight: 4.1kg

To maintain the IPX2 rating of the unit, the unit must not be mounted with the cover removal slots facing upwards, or at an angle where they are visible from above. All other orientations are acceptable.

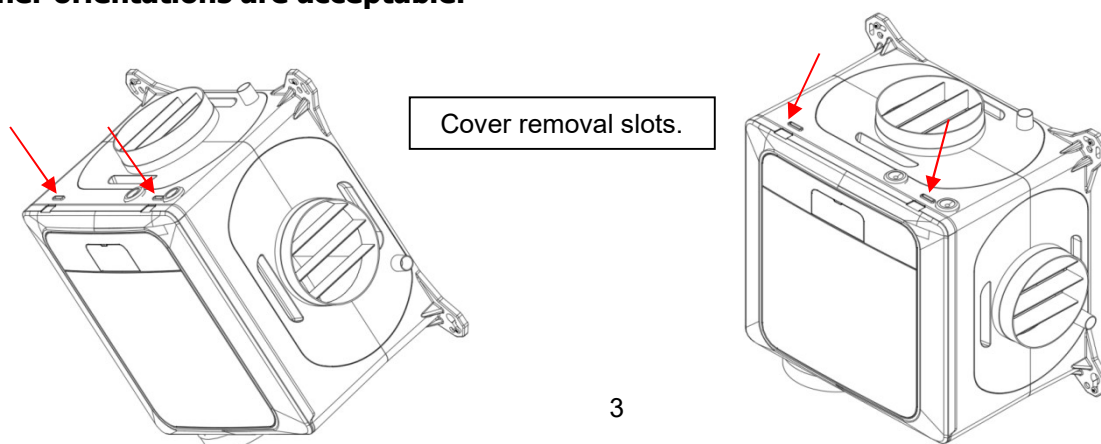

See the dimensional details below for the mounting hole positions.
-Spigot diameters are 125mm

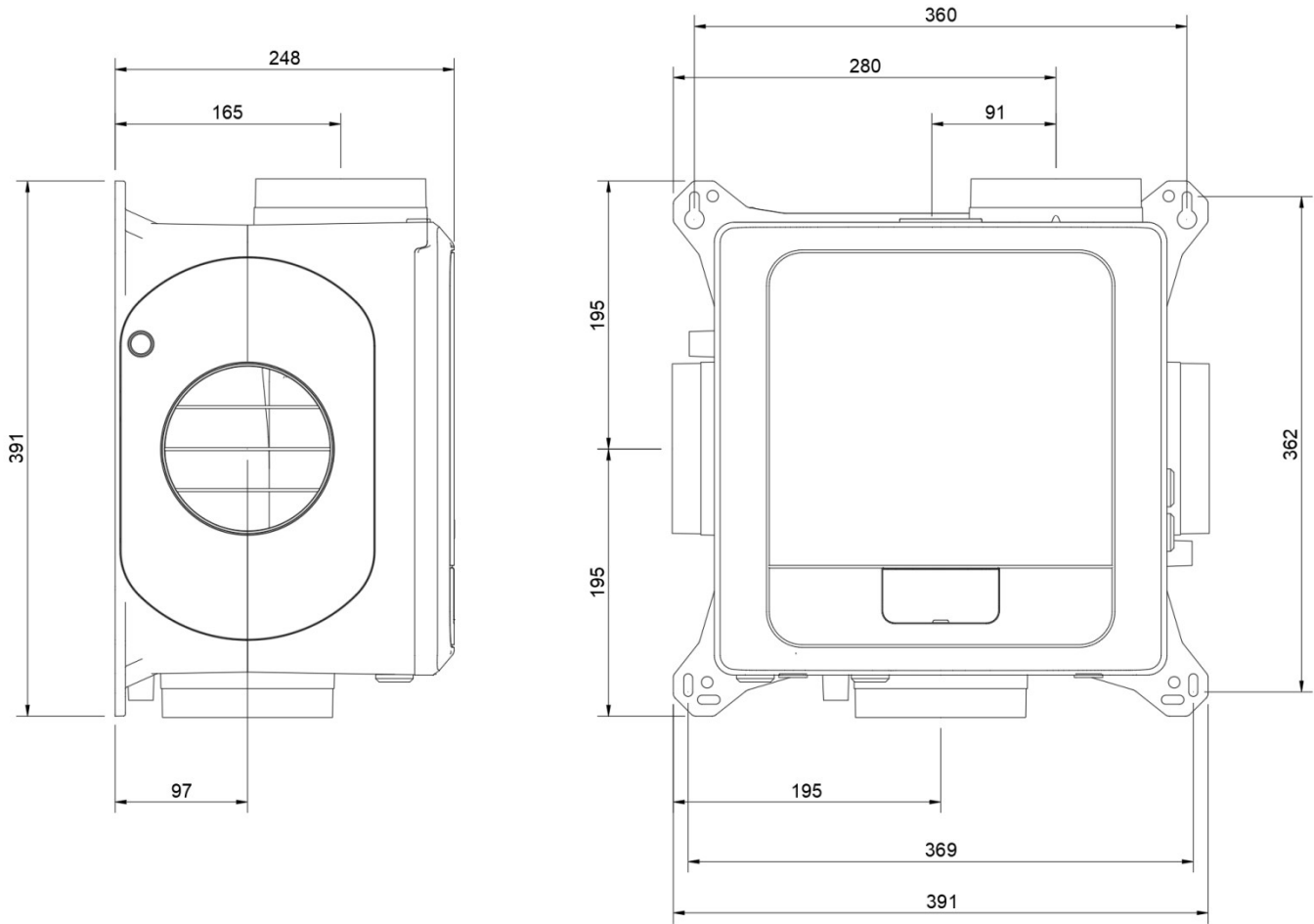

i. **Base mounted Installation** with ducting radiating out horizontally.

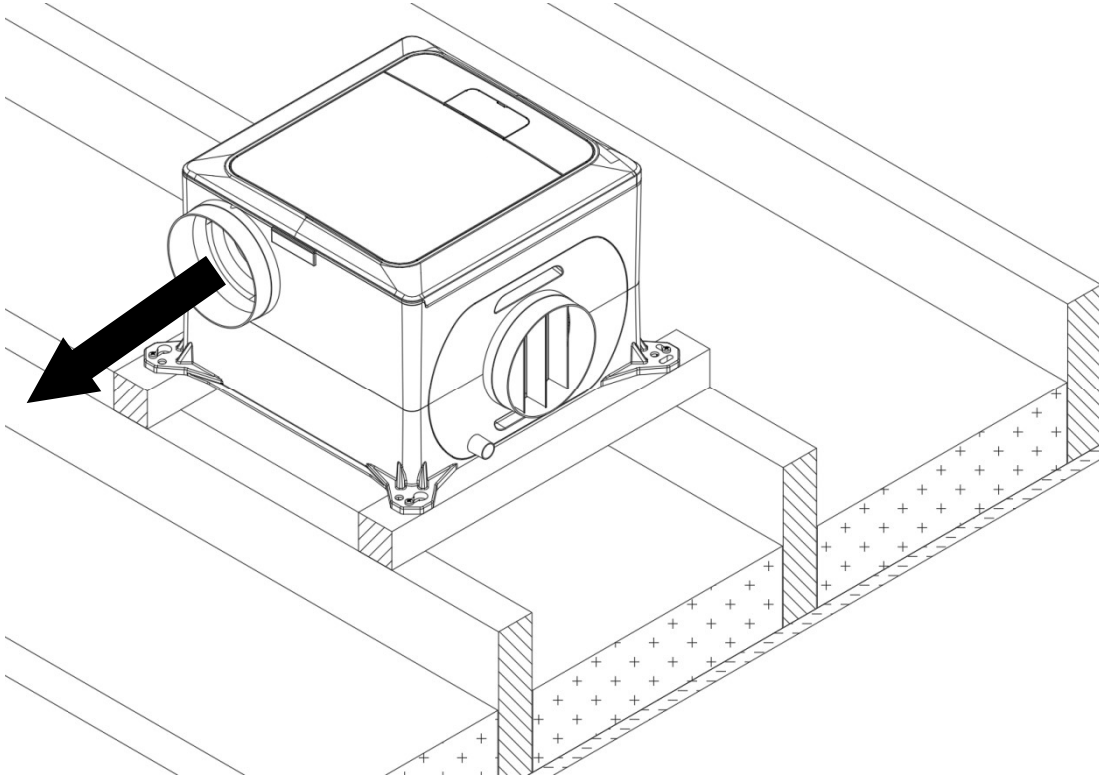

ii. **Vertically mounted Installation** with the exhaust spigot at top. The electrical connections must come out of the bottom of the unit in order to maintain the water ingress protection.

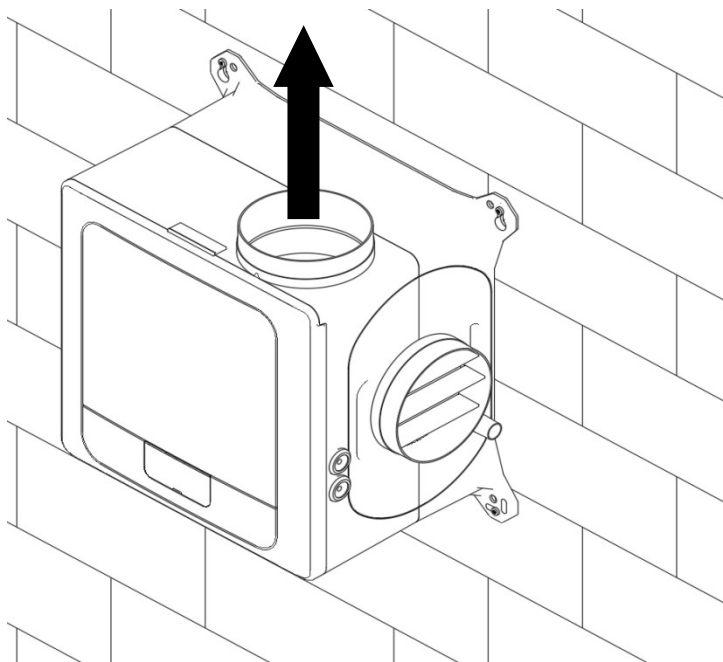

iii. **Ceiling mounted Installation** with ducting radiating out horizontally.

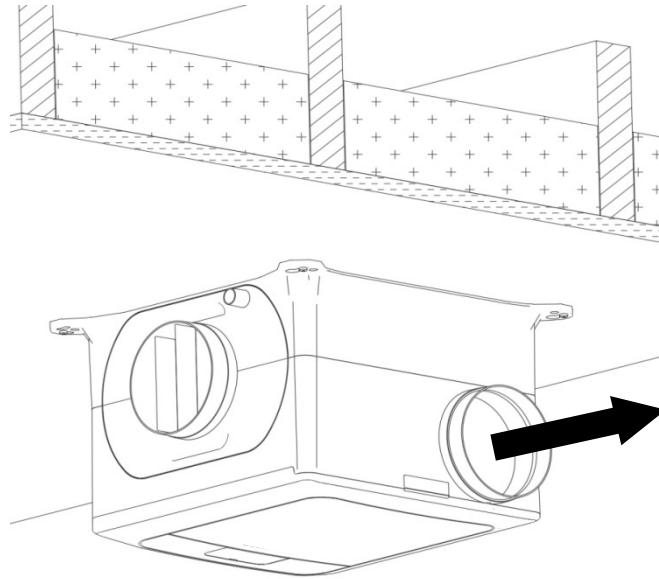

WIRING



WARNING:
THE UNIT AND ANCILLARY CONTROL EQUIPMENT MUST BE ISOLATED FROM THE POWER SUPPLY DURING THE INSTALLATION / OR MAINTENANCE. THIS UNIT MUST BE EARTHED.

1. To remove the cover, use a coin or similar; depress the retaining tabs via the slots in the side of the unit.
2. With the power off, connect a suitable mains power cable from a switched, fused spur to the screw terminal block. Use the cable clamps and clip provided to secure the lead.
3. Two mains voltage Live Switched (LS1 and LS2) connections are provided, and can be used to trigger a change in speed. Common inputs would be from a bathroom lighting circuit. When commissioning the unit, a delay on timer and an overrun timer can be selected and adjusted in the software using the buttons and screen. See commissioning section on page 7 of this document for details.
4. The switched live output (230Vac) from any other switch or controller, (such as a simple latching pull cord or push-button switch, humidistat or PIR detector) can be connected to the LS terminal instead of connecting to a lighting circuit.
5. Important: Use 4-core, low voltage, twisted pair, telecoms type cable for accessories. Accessories are connected via the IO (Input Output) PCB; see the Low Voltage Connections diagram. Use the cable clamp and grommet provided.
6. There are no delay on or overrun timers with the volt-free connection as the controller should determine when the fan is running at Boost or Normal speeds. Use the LS connection described above if you want a timer.
7. If a humidity sensor is fitted, the unit uses Ambient Response technology to adjust the fan speed proportionally depending on the temperature and relative humidity levels in the extracted air. The unit does not just look for relative humidity levels above a set point, which can be unreliable in products that extract from multiple rooms, but it also looks for rapid increase in relative humidity typically generated by such activities as showering or cooking. The sensor control also avoids nuisance tripping at nighttime when temperatures drop and relative humidity naturally rises.

CONNECTION DIAGRAM

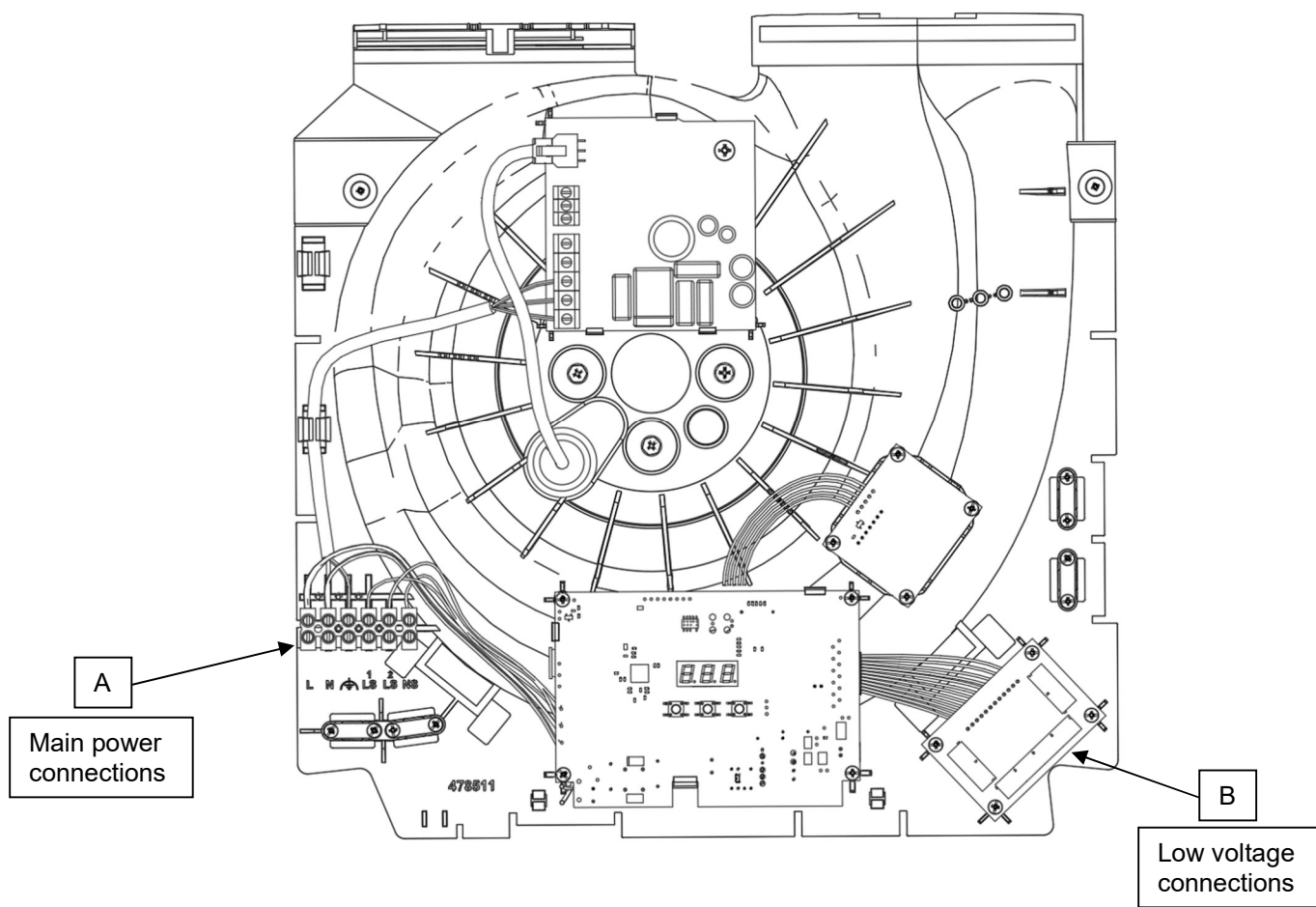

A: Main power connections

The LS1, LS2 and NS terminals are electrically isolated.

Note: Neutral link between 2 & 6 should be removed if different RCD protection circuits are used for mains power a & Live Switch connections.

Note: Ensure all live & neutral are isolated before servicing.

This appliance incorporates an earth connection for functional purposes only.

Connection	Description
1	L
2	N
3	 Functional Earth
4	LS1
5	LS2
6	NS
7	N + NS

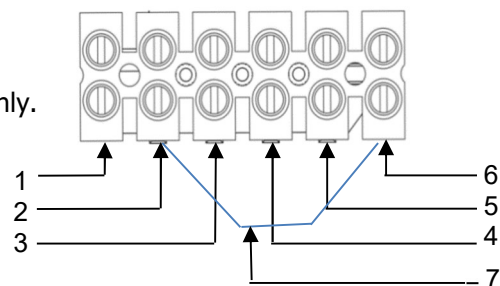

B: Low voltage connections

For best performance use 4-core, low voltage, twisted pair, telecoms type cable for accessories.

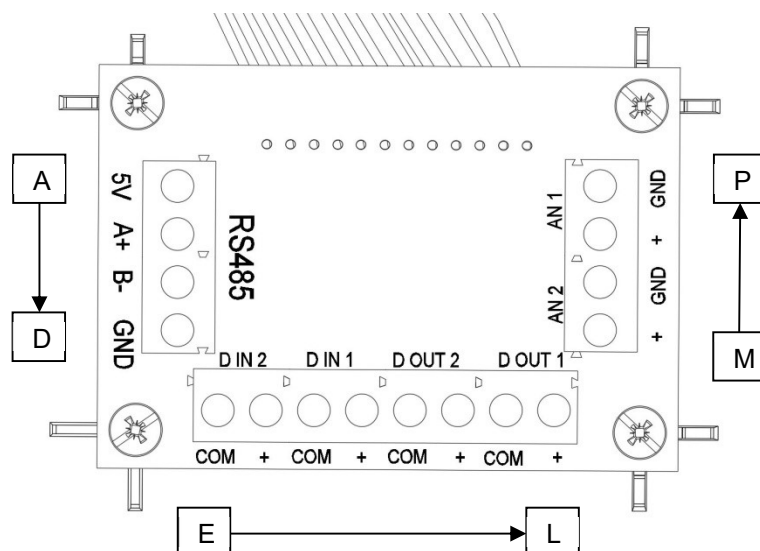

Position	Label	Description	Action
A	RS485	5V	RS485 communication to wired accessories. Data connection is only available for SMV/SMV Plus units. The 5V and Ground connections are available on all units.
B		A+	
C		B-	
D		GND	
E	D IN 2	COM	Go to Boost speed (Min.1V, max. 6V). The 5V output from the RS485 connection can be used as a power supply
F		+	
G	D IN 1	COM	Go to Low speed (Min.1V, max. 6V). The 5V output from the RS485 connection can be used as a power supply
H		+	
I	D OUT 2	COM	Unpowered Boost indicator Switch (switching 6V 50mA max)
J		+	
K	D OUT 1	COM	Unpowered LED fault indicator switch (switching 6V 50mA max)
L		+	
M	AN 2	+	0-10V analogue input. Two user settable voltage thresholds with two user settable actions. The unit will run at Normal when supplied voltage is between the two thresholds.
N		GND	
O	AN 1	+	
P		GND	

COMMISSIONING

Advanced feature descriptions

Comfort mode

If Comfort mode is enabled the unit will behave as follows for LS1 input:

Trigger	Action
LS1 input active less than 5 minutes	No action
LS1 input active more than 5 minutes but less than 20 minutes	Once LS1 input is removed, fan will run at user selected speed for the length of time LS1 was present plus the set over-run time (if over run is enabled).
LS1 input active more the 20 minutes	Unit will Boost after 20mins. Once LS1 input is removed, fan will run at user selected speed for 20 minutes plus the set over-run time (if over run is enabled).

The times are not adjustable by the user.

Humidity – Rapid rise

Rapid Rise humidity response functions to detect rapid rises in humidity when the ambient %RH is under the threshold setting. If a rapid rise is detected the fan will boost until the humidity lowers again.

Humidity – Ambient response

When ambient response is enabled the threshold set point is modified based on the ambient temperature. This helps to prevent nuisance boosting of the unit as temperatures changes during the day.

Analogue inputs

Both analogue inputs have adjustable low and high trigger voltages within the 0-10V range.

The response to being above or below either of the threshold voltages is user settable.

The display doesn't show a decimal point, for example at threshold voltage of 5.2V, is displayed as "52" on the unit.

Unit adjustment

1. Commissioning and configuration on all products is supported by the 3 digit user interface and associated push buttons.
2. When powered on, the unit will display the firmware revision number, after a few seconds the unit will display the first option in the menu structure (see below).
3. The display will enter standby mode after defined timeout (default 10min) or user selects "END" option in menu, press the Mode button to turn the display back on.
4. Changes to the settings can be made via the + and - buttons, the Mode button will accept changes and move onto the next menu option.
5. When setting the speeds, there is an internal logic: Low<Normal<Boost<Purge. I.e., Boost is always higher than Normal.
6. The actions for each of the Live Switched (LS), inputs are selectable. The setting for delays and over run timers are applicable to all inputs.
7. To restore factory settings, Press and hold "Mode" button for 10 seconds

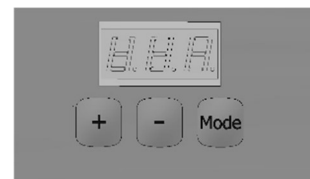

User Configurable Parameters

Display text	Function	Selections	Default
Lxx	Low speed	1 to 97% motor speed	10%
nxx	Normal speed	2 to 98% motor speed	35%
bxX	Boost speed	3 to 99% motor speed	70%
Pxx	Purge Speed	4 to 100% motor speed	100%
LS1	Live switch 1	Low, Boost or Purge speed	Low
LS2	Live switch 2	Low, Boost or Purge speed	Boost
LS3	Live switch 1&2	Low, Boost or Purge speed	Purge
c-n	Comfort mode	Comfort mode - yes or no	No
d-n	Delay On	Delay on - yes or no	No
dxx	Delay On time	Delay to boost duration 1 to 60 minutes	10m
o-n	Overrun	Overrun - yes or no	No
oxX	Overrun time	Overrun duration 1 to 60 minutes	10m
r-n	Humidity – Rapid Rise	Rapid rise - yes or no	Yes
A-n	Humidity – Ambient Response	Ambient response - yes or no	No
hxx	Humidity threshold	Ambient response threshold 40 to 90% RH	70%
C2b	CO2 threshold boost	Boost threshold 650 – 4950 PPM in increments of 50	100
C2P	CO2 threshold purge	Purge threshold 700 – 5000 PPM in increments of 50	195
A1LA	Analogue 1 - low action	Low, Normal, Boost or Purge speed	Low
A1HA	Analogue 1 - high action	Low, Normal, Boost or Purge speed	Purge
A1tL	Analogue 1 - low threshold	Analogue Input Threshold Low 1 - 99	15
A1tH	Analogue 1 - high threshold	Analogue Input Threshold High 1 - 99	75
A2LA	Analogue 2 - low action	Low, Normal, Boost or Purge speeds	Low
A2HA	Analogue 2 - high action	Low, Normal, Boost or Purge speeds	Purge
A2tL	Analogue 2 - low threshold	Analogue Input Threshold Low 1 - 99	15
A2tH	Analogue 2 - high threshold	Analogue Input Threshold High 1 - 99	75
D1	Digital input 1 Action	Low, Boost or Purge speeds	Low
D2	Digital input 2 Action	Low, Boost or Purge speeds	Purge
unl	Unlock code	Turn on/off the menu lock	---
PIIn	Display Pin	3 characters A to 9	LoC
dtXX	Display time	Adjust how long the display is illuminated	1-99 min
rot	Rotate display	Invert the display	rot
hu	Humidity	Show the current internal humidity	%
tu	temperature	Show the current internal temperature	°C
CO2	CO2	Show the current CO2 level	PPM
rEf	Calibration reference value	40 to 200	40 (400ppm)
cAL	Calibration Mode	Y to enable	n
end	end	End of menu (loop to start)	

If the unit being commissioned is not fitted with the relevant hardware, the associated menu options will not be available.

SERVICING & MAINTENANCE



WARNING: THE FAN AND ANCILLARY CONTROL EQUIPMENT MUST BE ISOLATED FROM THE POWER SUPPLY DURING MAINTENANCE.

1. At intervals appropriate to the installation, the fan should be inspected and cleaned to ensure there is no significant buildup of dirt or other deposits.
2. To inspect the inside of the product isolate the power, use a coin or similar to depress the cover retention clips.
3. Remove the cover; remove the scroll assembly by unscrewing the two screws and unclipping the clips in the two corners and pulling away. If necessary, vacuum the inside of the MVDC Unit.
4. The fan has sealed for life bearings, which do not require lubrication. Expected service life is at least 45,000 hours continuous running.
5. Check all fixings are tight and secure

FAULT CODES

If the MEV unit detects a fault it will display an error message on the HMI display:

Fault Code	Description	
F01	Control fault – Unit failed startup check	Turn the power off and on again.
F02	Motor Fault – No RPM	Check that the impellor has free movement. Check internal motor wiring.
F03	Humidity/Temp sensor Fault – No value – internal sensor	Contact tech support, scroll part.
F04	CO ₂ sensor Fault – No value – internal sensor	Check the internal wiring to the sensor
F05	Temp or Humidity sensor connected via RF/RS485 is offline/Lost	Check that the sensor is turned on. Re-pair the sensor to the unit, see page 10.
F06	CO ₂ sensor connected via RF/RS485 is offline/Lost	Check that the sensor is turned on. Re-pair the sensor to the unit, see page 10.
F07	4-Way Speed Switch	SSU offline or lost – Please reconnect
F08	AIM (Alarm Interface Module)	AIM Sensor triggered / offline or lost – Verify Issue

If a fault persists, contact your local technical support, see the back cover of this manual for details.

OPTIONAL ACCESSORIES

Sensor/Controller Name / Function	MON-MEVDC400 / MON-MEVDCH400
	Wired 0-10V
Temp/RH	MONMEV-T/RH (240V)
CO ₂ (+RH) 0-10V	MONMEV-CO ₂ /RH (240V)
4-Way Analogue Speed Switch	MONMEV-4SS (240V)

SPARE PARTS

Scroll assembly - Please contact:
National Ventilation Technical support
+44 (0) 1823 690290

Email: info@nvagroup.co.uk

Name:	Monsoon	
Model ID (Stock Ref.) :	MON-MEVDC400	MON-MEVDCH400
SEC Class	B	
SEC Value ('Average')	-27.2	
SEC Value ('Warm')	-11.7	
SEC Value ('Cold')	-54.3	
Label Required? (Yes/No=Out of scope)	Yes	
Declared as: RVU or NRVU/UVU or BVU	RVU/UVU	
Speed Drive	Multi Speed	
Type HRS (Recuperative, Regenerative, None)	None	
Thermal Eff: [(%), NA(if none)]	N/A	
Max. Flow Rate (m3/h)	338.8	
Max. Power Input (W): (@Max.Flow Rate)	43	
LWA: Sound Power Level dB)	46.4	
Ref. Flow Rate (m3/s)	0.066	
Ref. Pressure Diff. (Pa)	201	

Product Fiche

SPI [W/(m ³ /h)]	0.07
Control Factor & Control Typology: (CTRL/ Typology)	
Control Factor; CTRL	0.65
Control Typology	Local Demand Control
Declared: -Max Internal & External Leakage Rates(%) for BVUs or carry over (for regenerative heat exchangers only), Ext. Leakage Rates (%) for Ducted UVUs;	<5% Internal, <5% External
Mixing Rate of Non-Ducted BVUs not intended to be equipped with one duct connection on either supply or extract air side;	N/A
Position and description of visual filter warning for RVUs intended for use with filters, including text pointing out the importance of regular filter changes for performance and energy efficiency of the unit	N/A
For UVUs (Instructions Install Regulated Supply/Extract Grilles Façade)	In F&W
Internet Address (for Disassembly Instructions)	www.nationalventilation.co.uk
Sensitivity p. Variation@+20/-20 Pa: (for Non-Ducted VUs)	N/A
Air Tightness-ID/OD-(m ³ /h) (for Non-Ducted VUs)	N/A
Annual Electricity Consumption: AEC (kWh/a)	0.4
Annual Heating Saved: AHS (kWh/a)	
AHS: Average	28.3
AHS: Warm	12.8
AHS: Cold	55.4



Disposal

This product should not be disposed of with household waste. Please recycle where facilities exist. Check with your local authority for recycling advice.



**NATIONAL
VENTILATION**

National Ventilation

Stathe Road
Burrowbridge
Somerset
TA7 0RY

Contact Information

Website: www.nationalventilation.co.uk
email: info@nvagroup.co.uk
Sales and technical hotline: 01823 690290

EU Authorised Representative: National Ventilation Bedrijvenweg 17 7442 CX Nijverdal Nederland authorisedrep@nationalventilation.nl

496200 C

0522