



MRXBOX-VSC

Visual System User Control

Installation and Maintenance

1.0 INTRODUCTION

The MRXBOX-VSC is a user control from the Ecosmart range.

These wall mounted user controls include a 3.5" colour LCD touchscreen display to provide improved user interface. The unit can be surface or semi-recessed mounted and is compatible with standard 2-gang recess back box. The control is manufactured from an all plastic construction and supplied with 10m of pre-plugged connection cable and surface mounting back box.

Units are SELV (12 Vdc) with the power supplied from the fan unit via the pre-plugged cable.

2.0 DIMENSIONS

Figure 1. Unit Dimensions

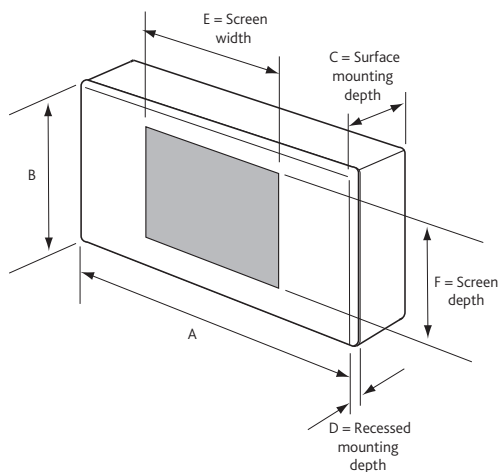

Dimensions	A	B	C	D	E	F
MRXBOX-VSC	145	85	35	6	73	57

3.0 INSTALLATION

IMPORTANT

INSTALLED ENVIRONMENT:
0-40°C and <90% RH (non-condensing)

Caution: The unit must be installed away from any direct source of heat (e.g. radiators) and not in areas where it would be subjected to steam or water spray.

The mounting surface must be free from vibration.

The unit is supplied with back box suitable for surface mounting (see Figure 2 - Figure 6).

If semi-recess (final projection from wall is approximately 7mm) is needed, a proprietary 2-gang back box (25mm deep minimum) may be used.

Always physically check the suitability of the back box before fitting. In some instances, the earthing point of the back box may foul the unit and need to be removed.

1. Fix one end of the 10m cable to the fan's Ecosmart connection point and route the cable to the mounting position.

2. Unclip the front bezel from the unit and remove the 2 retaining screws, then remove the working section from the back box (see figure Figure 3).
3. Feed the cable through the knock-out hole in the base of the back box and mark the fixing point on the wall, drill appropriately sized holes at the required fixing points and insert the wall plugs. Fix the back box on to the wall (see figure Figure 4).
4. Plug the data cable into the socket (see figure Figure 5).
5. Fix the unit back into the back box using the screws supplied, then clip the bezel back on the unit again noting which way is up. (Top is printed on the inside face of the bezel and middle section) (see figure Figure 6).

Figure 2.

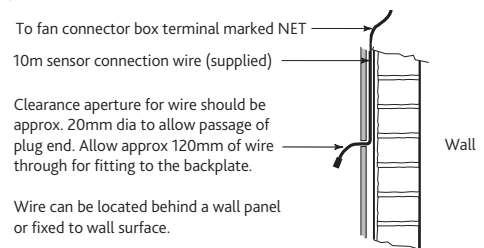

Figure 3.

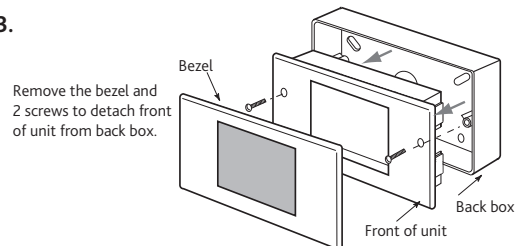

Figure 4.

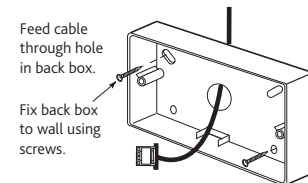

Figure 5.

Plug end mounted into the PCB socket inside the front half of the unit. Note that the data cable socket is positioned at the top corner of the unit.

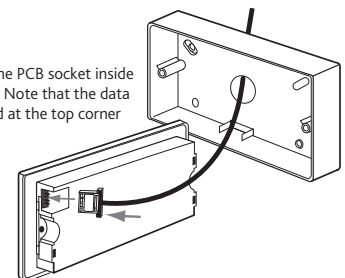
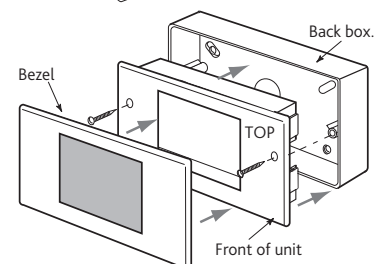

Figure 6.



3.1 Data Cable Installation

A 4-core SELV data cable is used to connect the control to the fan.

Do not run data cable in the same conduit as the mains cables and ensure there is a 50mm separation between the data cable and other cables.

For cable lengths in excess of 10m a MRXBOX-JB will be required to provide sufficient power. Keep the number of cable joints to a minimum to ensure the best data transmission efficiency between devices.

IMPORTANT

Due to the higher current consumed by the MRXBOX-VSC, the maximum cable run between the fan control and the MRXBOX-VSC must be limited to 50m.

4.0 OPERATING MRXBOX-VSC

Using the Visual display screen will override any unit mounted controls.

4.1 The Home Screen

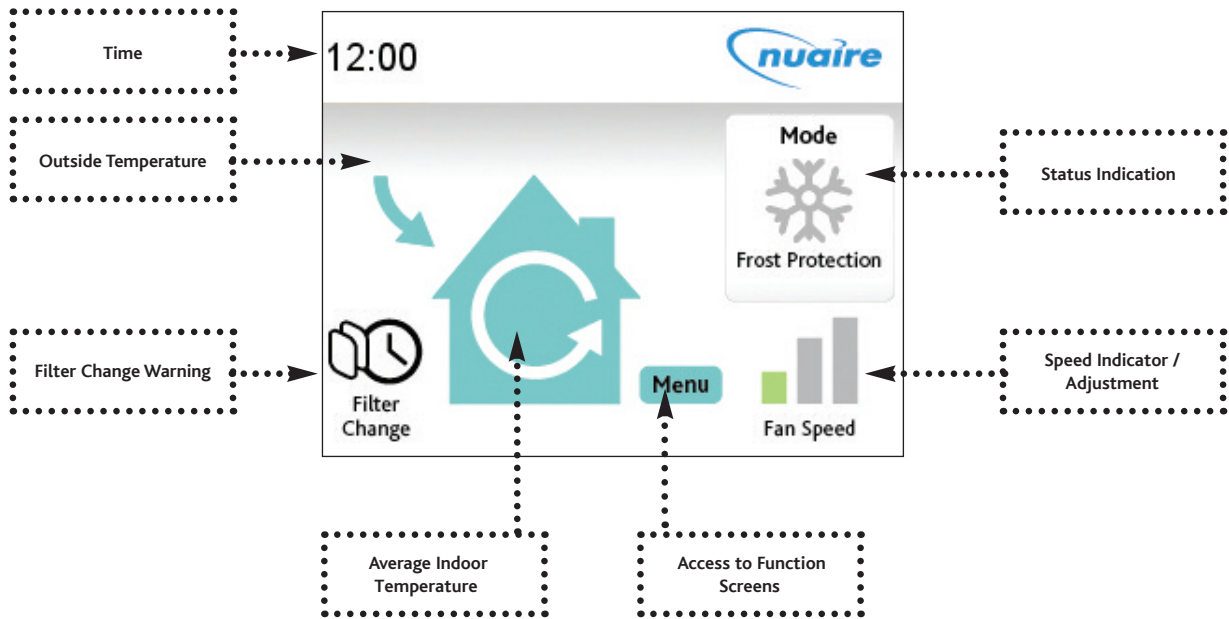

4.2 The Settings Screen

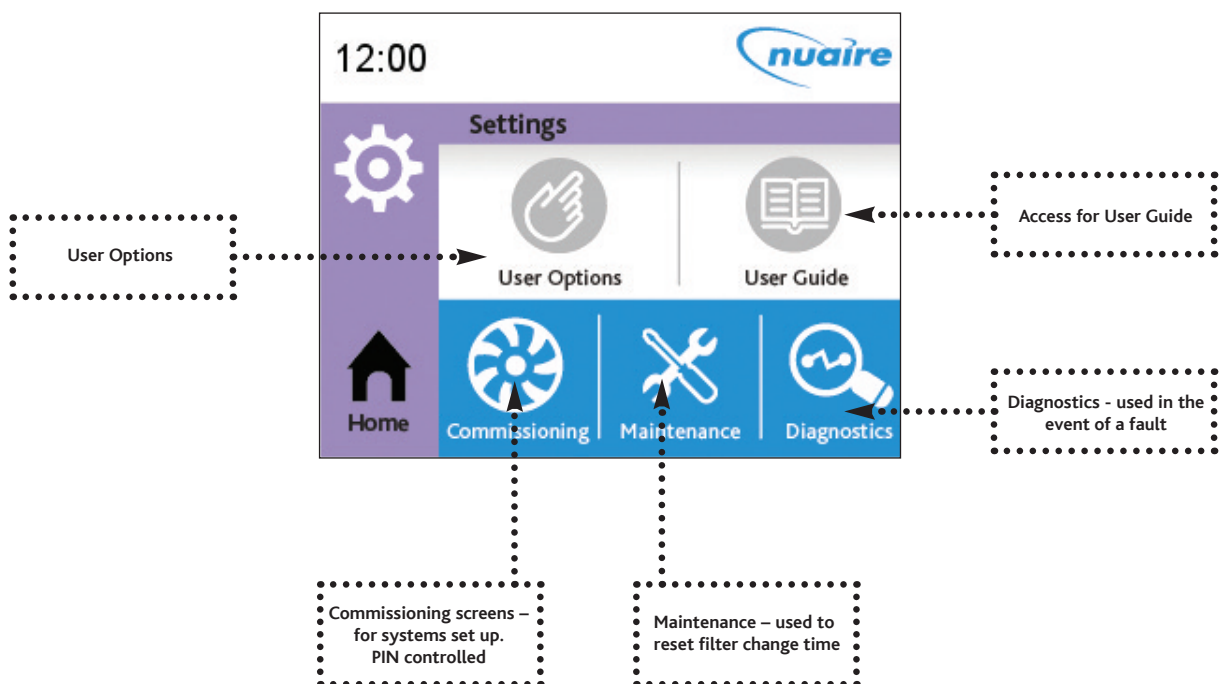

5.0 USER INTERFACE

5.1 User Options Screen

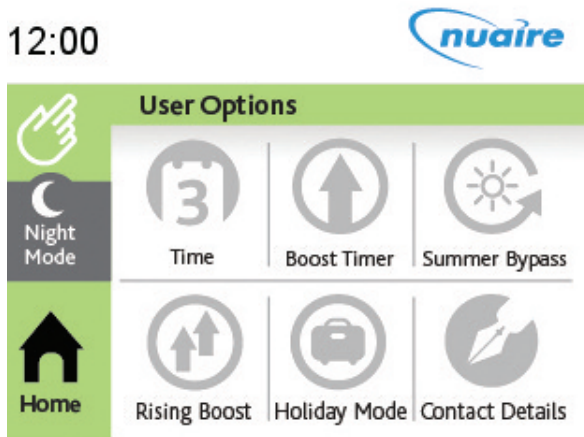

5.2 Night Time Mode

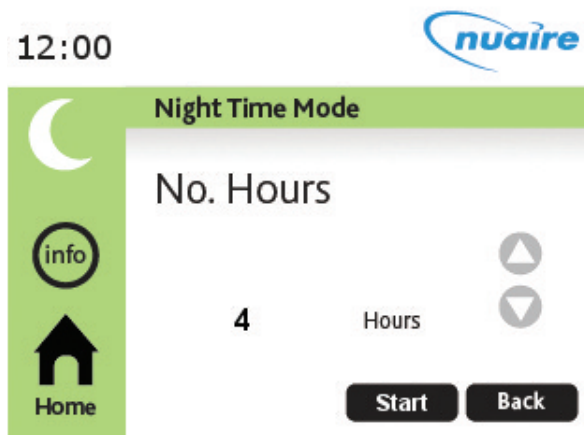

Night Mode – Allows you to set the ventilation system to run at a minimum level at night; adjustable between 4 and 8 hours. This feature can also be de-selected from this screen when in operation.

5.3 Time

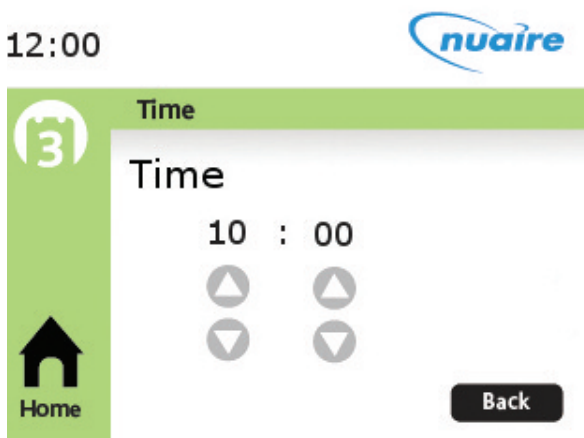

Time – Should be set on commissioning to ensure filter reminder is accurate.

5.4 Timed Boost

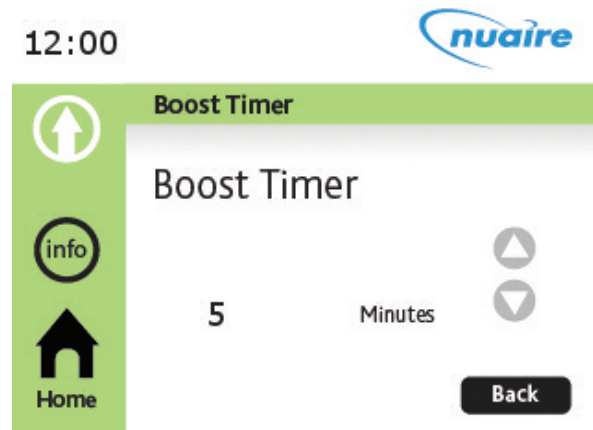

Timed boost – Allows you to adjust the time the ventilation system boosts when the speed setting is changed via the home screen, this can be set between 1 and 60 minutes. **Note: do not select "NONE" as this function is not operational in this format.**

Note: The speed of the unit may also be controlled by other sensors fitted, some of which may have built-in run on functionality.

5.5 Summer Bypass

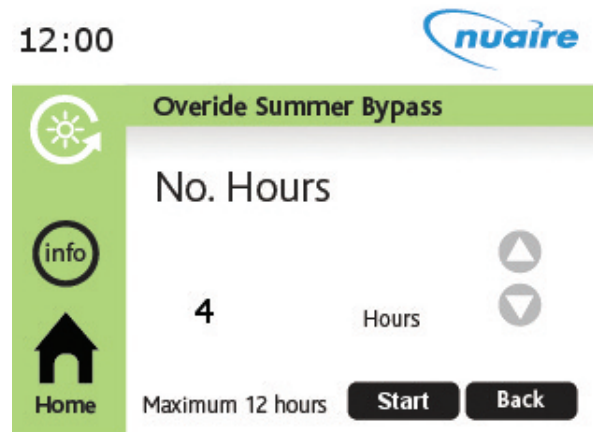

Summer Bypass – When the weather is warm outside, the unit will automatically go into summer bypass mode, meaning the air coming into your home will not pass through the heat exchanger in the ventilation unit. This button allows you to manually activate this feature, should you wish to prevent the air coming into your home being warmed. Summer bypass is set at a default 4 hours, but you can adjust this to a maximum of 12 hours in the User Options.

This feature can also be de-selected from this screen when in operation.

5.6 Rising Boost

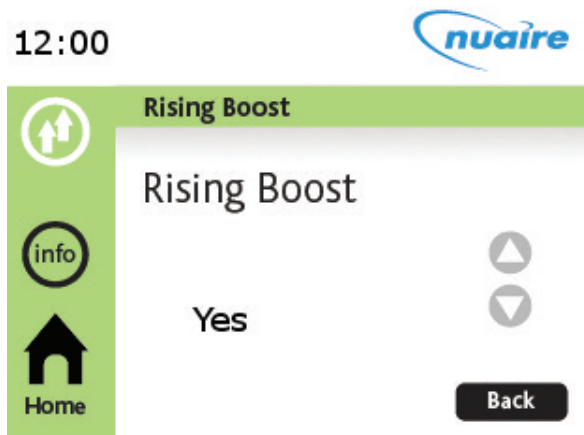

Rising Boost – Allows you to set the ventilation system so that the speed of the fan increases gradually, instead of going straight into full boost.

5.7 Holiday Mode

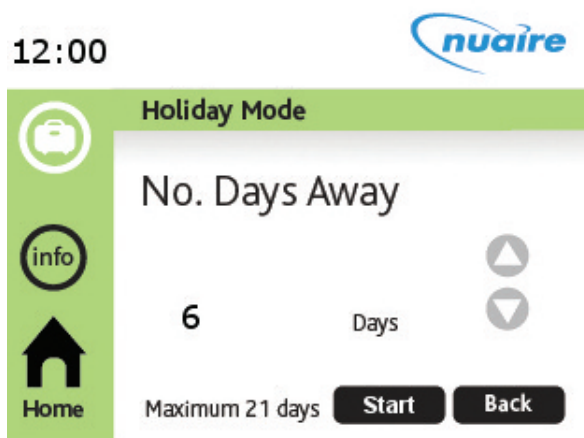

Holiday Mode – Allows you to set the ventilation system to run at a minimum level while you are away. You can adjust the number of days you are away for, with a maximum of 21 days.

6.0 Commissioning

6.1 Commissioning Screen

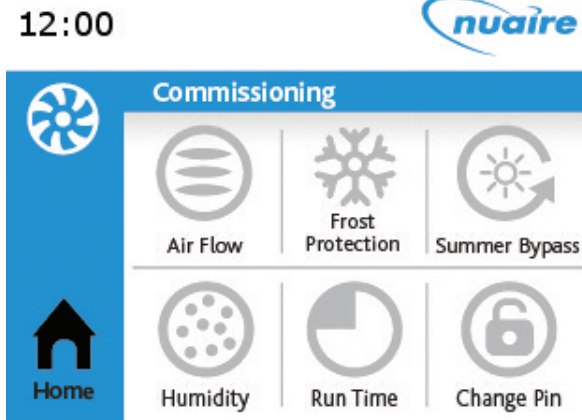

Commissioning – This should be carried out with reference to the ventilation units specific installation and maintenance instructions. By using the MRXBOX-VSC, any controls on the front of the unit will become inoperable.

Note: The adhesive backed commissioning label fitted to the front panel of the ventilation unit should still be applied to seal the commissioning pot access holes.

6.2 Air Flow

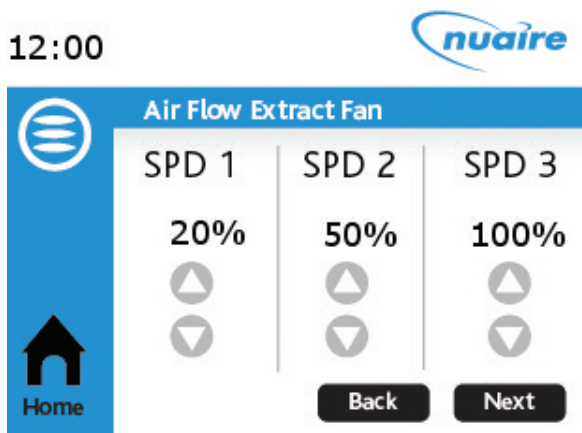
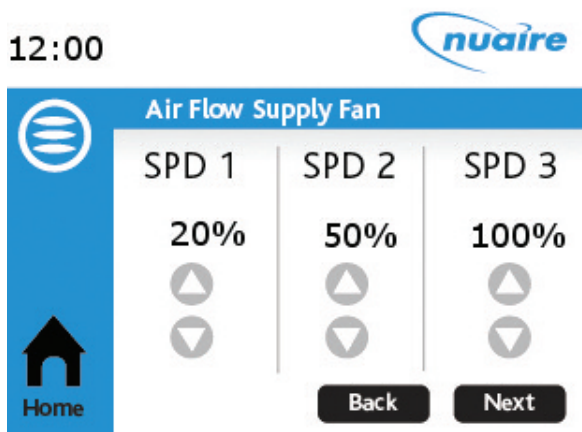

Air Flow – Gives individual control of the supply and extract flow rates. The commissioning Engineer should follow the requirement for speed 1 (trickle) and speed 2 (boost) as per Building Regulation Part F ventilation and detailed in the Installation instructions for the unit. Speed 3 is for purge ventilation and is recommended to be set to 100%.

Note: Speed 2 cannot be adjusted to a lower value than speed 1.

6.3 Frost Protection

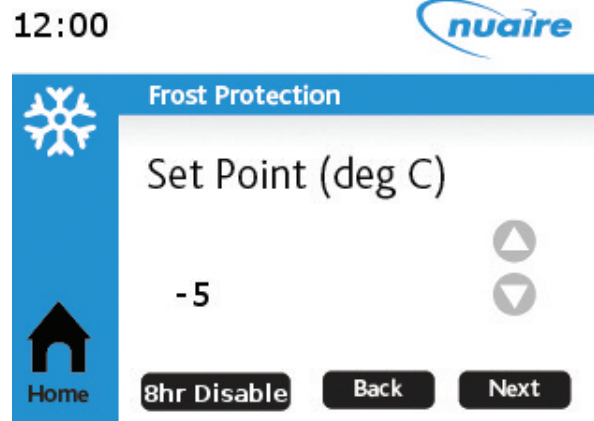

Frost Protection – In the event of the outdoor temperature falling below a set rate to unit reduces the supply fan speed down to a minimum to prevent the unit freezing. The default temperature for frost protection to activate is -5°C. This can be raised to a maximum of 0°C if required.

Note: This function can be disabled for 8 hours to assist commissioning.

6.4 Summer Bypass (where fitted)

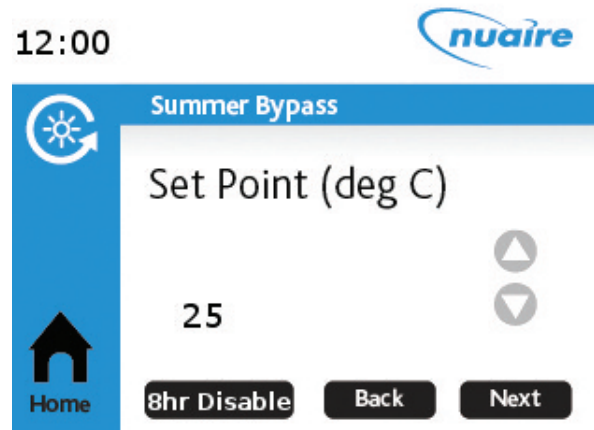

Summer Bypass – The ventilation unit uses this feature to try and maintain a set temperature in the household. By default this is 25°C although this figure can be adjusted between 15 and 30°C if desired.

Note: This function can be disabled for 8 hours to assist commissioning.

6.5 Humidity (where fitted)

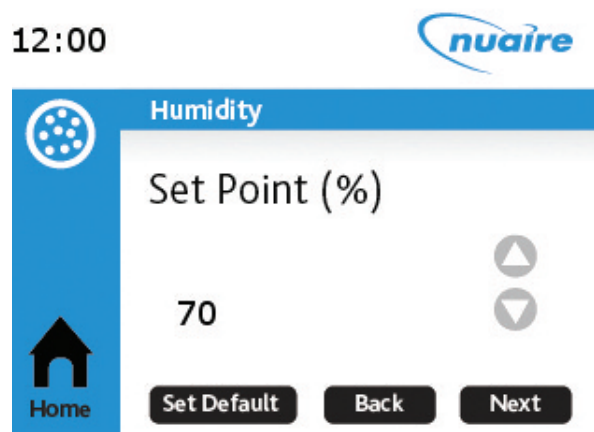

Humidity – The unit monitors the humidity level of the whole property and boosts the unit if the level exceeds the set point.

It is recommended to set the relative humidity to 70%.

6.6 Run-Time



Run-Time – This shows the duration the unit has been on and off.

6.7 Change PIN

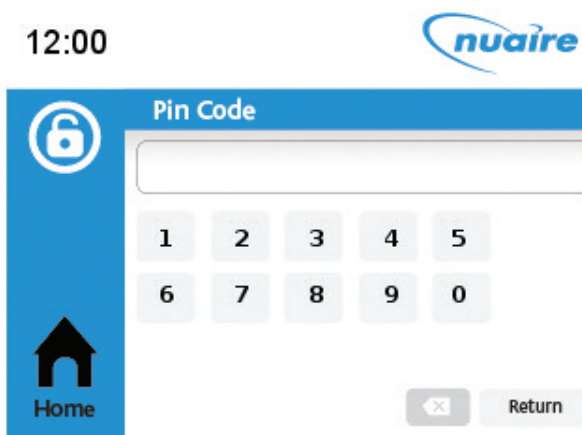

Change PIN – Used to enter a PIN code. As a default 1234 is used. PIN codes are used to prevent the occupant tampering with the commissioned levels.

7.0 USER GUIDE



8.0 COMPATIBILITY WITH ECOSMART FAN

The MRXBOX-VSC controller is 100% compatible with the Ecosmart fans and air handling units supplied with the controller.

However, some other products may not be so. Please check the suitability of the fan unit before upgrading the existing user control to the MRXBOX-VSC controller.

To check if the fan is suitable for upgrade, please contact Nuaire with detail of the fan code and the serial number printed on the rating label.

9.0 DIAGNOSTICS

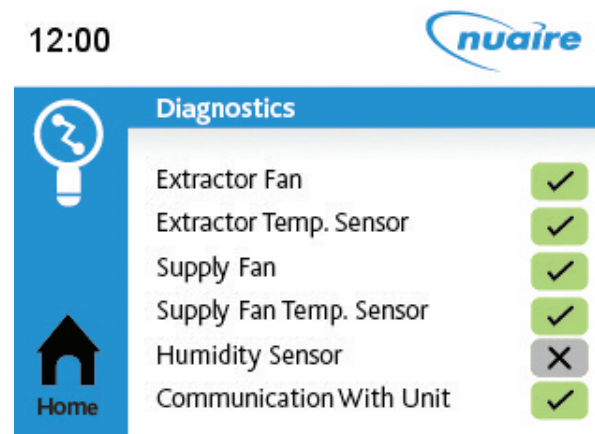

Diagnostics – If a fault is suspected the diagnostics screen can be accessed to view the status of the unit controls, a cross indicates an issue.

In the case that the communication is lost to the unit a '?' will be shown against all other features. If the unit has gone into failure mode it may be necessary the unit is switched off for 30 seconds and then turned back on to re-access the status of the controls.

Note: In the case of fault only qualified persons should undertake any investigation or corrective actions. Please refer to the ventilation units' specific Installation and Maintenance document for information and guidance.

10.0 MAINTENANCE

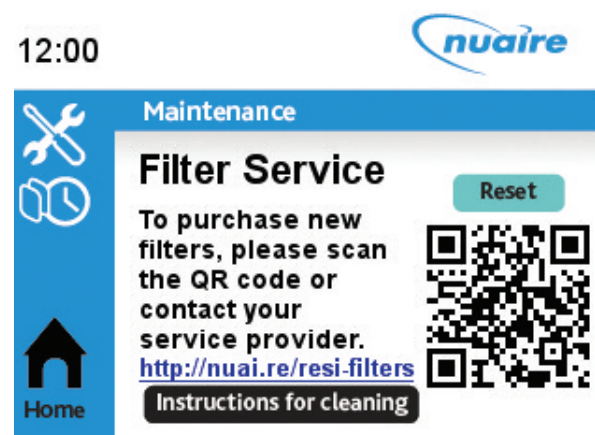

Maintenance – After a pre-determined length of time the unit will display an icon on the home screen indicating that the filters should be changed. Once this task has been completed the feature can be reset from the maintenance screen to clear the icon. Instructions on how to complete this task can also be found on this screen.

11.0 WARRANTY

The 5 year warranty commences on the day of delivery and includes parts and labour for the first year. The remaining period covers replacement parts only. The labour content is subject to full, free and safe access to the equipment as recommended by the CDM regulations. The warranty excludes any damage to the LCD touch screen caused by misuse of a sharp object.

This warranty is void if the equipment is modified without authorisation, is incorrectly applied, misused, disassembled, or not installed, commissioned and maintained in accordance with the details contained in this manual and general good practice.

The product warranty applies to the UK mainland and in accordance with Clause 14 of our Conditions of Sale. Customers purchasing from outside of the UK should contact Nuair International Sales office for further details.

12.0 AFTER SALES ENQUIRIES

For technical assistance or further product information, including spare parts and replacement components, please contact the After Sales Department.

Telephone 02920 858 400
aftersales@nuaire.co.uk

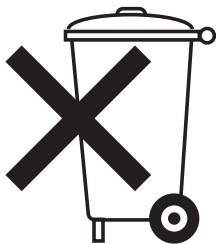

Note: This unit contains a small lithium battery and must be disposed of by a suitable recycling centre.

**Do not dispose of with normal household waste.
Do not burn.**

Technical or commercial considerations may, from time to time, make it necessary to alter the design, performance and dimensions of equipment and the right is reserved to make such changes without prior notice.

FOR MORE INFORMATION

www.nuaire.co.uk

COMMERCIAL

www.nuaire.co.uk/commercial

AIR HANDLING UNITS

www.nuaire.co.uk/boxerahu

BIM

www.nuaire.co.uk/bim



NUAIRE LIMITED

Western Industrial Estate | Caerphilly | CF83 1NA

t +44 (0)29 2085 8200 | f +44 (0)29 2085 8222 | e info@nuaire.co.uk

www.nuaire.co.uk

As part of our policy of continuous product development Nuaire reserves the right to alter specifications without prior notice.

Telephone calls may be recorded for quality and training purposes.